



FEATURES

- 105°C 3,000 ~ 5,000 hours assured
- Ultra low impedance capacitors
- RoHS compliant

SPECIFICATIONS

Items	Performance																														
Operating Temperature Range	6.3 ~ 100V																														
	-55°C ~ +105°C																														
Capacitance Tolerance	± 20% (at 120 Hz, 20°C)																														
Leakage Current at 20°C	I = 0.01CV or 3 (μA) whichever is greater (after 2 minutes) Where, C= rated capacitance in μF, V= rated DC working voltage in V																														
Disipation Fa ctor (Tan δ) at 120Hz, 20°C	<table border="1"> <thead> <tr> <th>Rated Voltage (Vdc)</th> <th>6.3</th> <th>10</th> <th>16</th> <th>25</th> <th>35</th> <th>50</th> <th>63</th> <th>80</th> <th>100</th> </tr> </thead> <tbody> <tr> <td>Tan δ</td> <td>0.24</td> <td>0.20</td> <td>0.18</td> <td>0.16</td> <td>0.14</td> <td>0.12</td> <td>0.12</td> <td>0.12</td> <td>0.12</td> </tr> <tr> <td>(max.)</td> <td>0.28</td> <td>0.24</td> <td>0.20</td> <td>0.18</td> <td>0.16</td> <td>0.14</td> <td>0.14</td> <td>0.14</td> <td>0.14</td> </tr> </tbody> </table>	Rated Voltage (Vdc)	6.3	10	16	25	35	50	63	80	100	Tan δ	0.24	0.20	0.18	0.16	0.14	0.12	0.12	0.12	0.12	(max.)	0.28	0.24	0.20	0.18	0.16	0.14	0.14	0.14	0.14
	Rated Voltage (Vdc)	6.3	10	16	25	35	50	63	80	100																					
Tan δ	0.24	0.20	0.18	0.16	0.14	0.12	0.12	0.12	0.12																						
(max.)	0.28	0.24	0.20	0.18	0.16	0.14	0.14	0.14	0.14																						
• When the capacitance exceeds 1,000μF, 0.02 should be added every 1,000μF increase.																															
Low Temperature Characteristics at 120Hz	<table border="1"> <thead> <tr> <th>Rated Voltage (Vdc)</th> <th>6.3</th> <th>10</th> <th>16</th> <th>25</th> <th>35</th> <th>50</th> <th>63</th> <th>80</th> <th>100</th> </tr> </thead> <tbody> <tr> <td>Impedance Ratio</td> <td>3</td> <td>3</td> <td>3</td> <td>3</td> <td>3</td> <td>3</td> <td>2</td> <td>2</td> <td>2</td> </tr> <tr> <td>ZT / Z20 (max.)</td> <td>4</td> <td>4</td> <td>4</td> <td>3</td> <td>3</td> <td>3</td> <td>3</td> <td>3</td> <td>3</td> </tr> </tbody> </table>	Rated Voltage (Vdc)	6.3	10	16	25	35	50	63	80	100	Impedance Ratio	3	3	3	3	3	3	2	2	2	ZT / Z20 (max.)	4	4	4	3	3	3	3	3	3
	Rated Voltage (Vdc)	6.3	10	16	25	35	50	63	80	100																					
	Impedance Ratio	3	3	3	3	3	3	2	2	2																					
ZT / Z20 (max.)	4	4	4	3	3	3	3	3	3																						
• Impedance ratio shall not exceed the values given in the table above.																															
Load Life Test (by can size)	<table border="1"> <thead> <tr> <th>Test Time</th> <th>3,000hrs: 4, 5, 6.3, 8x6.5, 10x7.7</th> <th>5,000 hrs for all others</th> </tr> </thead> <tbody> <tr> <td>Capacitance Change</td> <td>Within ±25% of initial value</td> <td>Within ±25% of initial value</td> </tr> <tr> <td>Disipation Fa ctor</td> <td>Less than 200% of specified value</td> <td>Less than 200% of specified value</td> </tr> <tr> <td>Leakage Current</td> <td>Within specified value</td> <td>Within specified value</td> </tr> </tbody> </table>	Test Time	3,000hrs: 4, 5, 6.3, 8x6.5, 10x7.7	5,000 hrs for all others	Capacitance Change	Within ±25% of initial value	Within ±25% of initial value	Disipation Fa ctor	Less than 200% of specified value	Less than 200% of specified value	Leakage Current	Within specified value	Within specified value																		
	Test Time	3,000hrs: 4, 5, 6.3, 8x6.5, 10x7.7	5,000 hrs for all others																												
	Capacitance Change	Within ±25% of initial value	Within ±25% of initial value																												
	Disipation Fa ctor	Less than 200% of specified value	Less than 200% of specified value																												
	Leakage Current	Within specified value	Within specified value																												
• The above specifications shall be satisfied when the capacitors are restored to 20°C after the rated voltage applied for 2,000~5,000hrs at 105°C																															
Shelf Life Test	Test Time: 1000 hrs; other items are the same as those for the load life test																														
Ripple Current & Frequency Multipliers	<table border="1"> <thead> <tr> <th>Frequency (Hz)</th> <th>50, 60</th> <th>120</th> <th>1K</th> <th>10K up</th> </tr> </thead> <tbody> <tr> <td>Multiplier</td> <td>0.60</td> <td>0.7</td> <td>0.85</td> <td>1</td> </tr> </tbody> </table>	Frequency (Hz)	50, 60	120	1K	10K up	Multiplier	0.60	0.7	0.85	1																				
	Frequency (Hz)	50, 60	120	1K	10K up																										
Multiplier	0.60	0.7	0.85	1																											

PAD SPACING AND DIAMETER

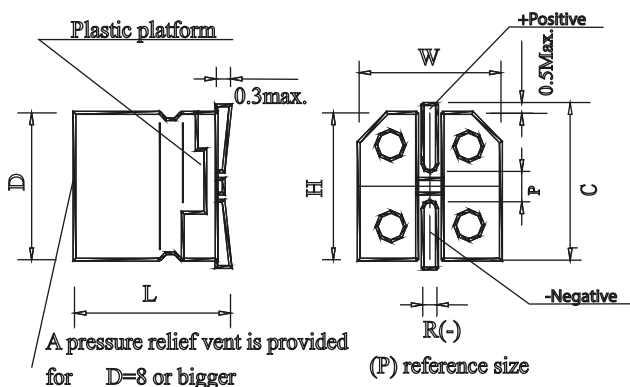

D ±0.5	L	W ±0.2	H ±0.2	C ±0.2	R	P ±0.2
4	5.8 ±0.4	4.3	4.3	5.1	0.5 ~ 0.8	1.0
5	5.8 ±0.4	5.3	5.3	6.1	0.5 ~ 0.8	1.3
6.3	5.8 ±0.4	6.6	6.6	7.3	0.5 ~ 0.8	2.2
6.3	7.7 ±0.4	6.6	6.6	7.3	0.5 ~ 0.8	2.2
8	6.5 ±0.5	8.3	8.3	9.2	0.7 ~ 1.2	3.1
8	10.5 ±0.5	8.3	8.3	9.2	0.7 ~ 1.2	3.1
10	7.7 ±0.5	10.3	10.3	11.2	0.7 ~ 1.2	4.4
10	10.5 ±0.5	10.3	10.3	11.2	0.7 ~ 1.2	4.4
10	13.5 ±0.5	10.3	10.3	11.2	0.7 ~ 1.2	4.4
12.5	13.5 ±0.5	13.0	13.0	14.0	1.0 ~ 1.4	4.4
12.5	16.0 ±0.5	13.0	13.0	14.0	1.0 ~ 1.4	4.4
16	16.5 ±0.5	17.0	17.0	18.0	1.0 ~ 1.4	6.4

MARKINGS

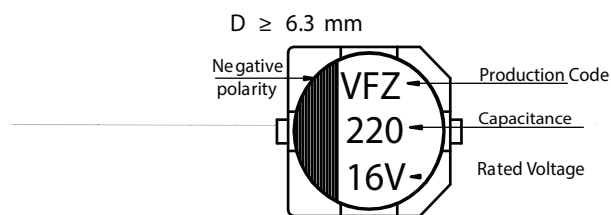

PART NUMBER EXAMPLE

<u>VFZ</u>	<u>101</u>	<u>M</u>	<u>1V</u>	<u>TR</u>	<u>080105</u>
Series	Capacitance Code	Tolerance Code	Voltage Code	Package Style	Can Size (8 x 10L)

■ DIMENSION, IMPEDENCE & PERMISSIBLE RIPPLE CURRENTS

Dimension: D x L(mm)

Ripple Current mA/rms at 100KHz, 105°C

Impedance: Ω at 100KHz, 20°C

μF	Vdc	6.3V			10V			16V			25V			35V		
		D x L	Imp.	mA	D x L	Imp.	mA	D x L	Imp.	mA	D x L	Imp.	mA	D x L	Imp.	mA
4.7	4R7															
10	100															
15	150															
22	220				4x5.8	1.45	90	5x5.8	0.76	170	5x5.8	0.76	170	5x5.8	0.76	170
27	270	4x5.8	1.45	90	5x5.8	0.76	170	5x5.8	0.76	170	6.3x5.8	0.44	250	6.3x5.8	0.44	250
33	330	5x5.8	0.76	170	5x5.8	0.76	170	6.3x5.8	0.44	250	6.3x5.8	0.44	250	6.3x5.8	0.44	250
47	470	5x5.8	0.76	170	6.3x5.8	0.44	250	6.3x5.8	0.44	250	6.3x5.8	0.44	250	6.3x5.8	0.44	250
56	560	5x5.8	0.76	170	6.3x5.8	0.44	250	6.3x5.8	0.44	250	6.3x5.8	0.44	250	6.3x7.7	0.34	300
68	680	6.3x5.8	0.44	250	6.3x5.8	0.44	250	6.3x5.8	0.44	250	6.3x5.8	0.44	250	6.3x7.7	0.34	300
100	101	5x5.8	0.76	170							6.3x7.7	0.34	300	6.3x7.7	0.34	300
		6.3x5.8	0.44	250	6.3x5.8	0.44	250	6.3x5.8	0.44	250	8x6.5	0.34	300	8x10.5	0.17	600
150	151	6.3x5.8	0.44	250	6.3x5.8	0.44	250	6.3x7.7	0.34	300	8x10.5	0.17	600	8x10.5	0.17	600
								8x6.5	0.34	300				10x7.7	0.17	600
220	221	6.3x5.8	0.44	250	6.3x7.7	0.34	300	6.3x7.7	0.34	300	8x10.5	0.17	600	8x10.5	0.17	600
					8x6.5	0.34	300				10x7.7	0.17	600			
330	331	6.3x7.7	0.30	300	8x10.5	0.17	600	8x10.5	0.17	600	8x10.5	0.17	600	10x10.5	0.090	850
		8x6.5	0.34	300				10x7.7	0.17	600						
470	471	8x10.5	0.17	600	8x10.5	0.17	600	8x10.5	0.17	600	10x10.5	0.090	850	10x13.5	0.070	950
					10x7.7	0.17	600							12.5x13.5	0.060	1100
680	681	8x10.5	0.17	600	10x10.5	0.090	850	10x10.5	0.090	850	10x13.5	0.070	950			
		10x7.7	0.17	600							12.5x13.5	0.060	1100	12.5x13.5	0.060	1100
1000	102							10x13.5	0.070	950				12.5x16.0	0.055	1200
		8x10.5	0.17	600	10x10.5	0.090	850	12.5x13.5	0.060	1100	12.5x13.5	0.060	1100	16x16.5	0.035	1800
1500	152				10x13.5	0.070	950				12.5x16.0	0.055	1200			
		10x10.5	0.090	850	12.5x13.5	0.060	1100	12.5x13.5	0.060	1100	16x16.5	0.035	1800	16x16.5	0.035	1800
2200	222	12.5x13.5	0.060	1100	12.5x13.5	0.060	1100	12.5x16.0	0.055	1200	16x16.5	0.035	1800			
2700	272				12.5x16.0	0.055	1200									
3300	332	12.5x16.0	0.055	1200	16x16.5	0.050	1450	16x16.5	0.035	1800						
4700	472	16x16.5	0.050	1800	16x16.5	0.035	1800									
6800	682	16x16.5	0.035	1800												

μF	Vdc	50V			63V			80V			100V		
		D x L	Imp.	mA	D x L	Imp.	mA	D x L	Imp.	mA	D x L	Imp.	mA
4.7	4R7	4x5.8	2.90	60	5x5.8	1.90	70				6.3x5.8	3.00	80
10	100	6.3x5.8	0.88	165	6.3x5.8	1.50	80				6.3x7.7	2.40	120
22	220	6.3x5.8	0.88	165	6.3x7.7	1.20	120				8x10.5	1.30	130
27	270	6.3x7.7	0.68	195				10x10.5	0.70	200			
33	330	6.3x7.7	0.68	195	8x6.5	1.20	120				10x10.5	0.65	200
47	470	6.3x7.7	0.68	195	10x7.7	0.70	200	10x10.5	0.65	200	12.5x13.5	0.32	500
56	560	8x10.5	0.34	350	10x10.5	0.50	300						
68	680	8x10.5	0.34	350				10x13.5	0.45	300	12.5x13.5	0.32	500
100	101	8x10.5	0.34	350	10x13.5	0.45	300	12.5x13.5	0.32	500	16x16.5	0.17	793
		10x7.7	0.34	350	12.5x13.5	0.16	800						
150	151	10x10.5	0.18	670	12.5x13.5	0.16	800	12.5x13.5	0.32	500	16x16.5	0.17	793
220	221	10x10.5	0.18	670	12.5x13.5	0.16	800	12.5x16.0	0.25	600			
330	331	12.5x13.5	0.12	900	16x16.5	0.082	1410	16x16.5	0.17	793			
470	471	16x16.5	0.073	1610	16x16.5	0.082	1410						
680	681	16x16.5	0.073	1610									
1000	102	16x16.5	0.073	1610									

■ CONSTRUCTION

Electrolytic paper

Electrolyte

Rubber seal

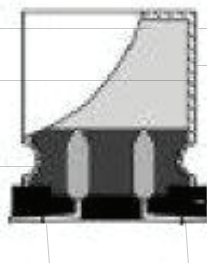

Aluminum case

Aluminum foil (anode & cathode foil)

Base plate

Lead wire

■ **PACKAGING SPECIFICATIONS**

JIS C0806 and IEC 60286, Surface Mount Type Taping Specifications in millimeters (mm)

■ **CARRIER TAPE: D≤10mm**

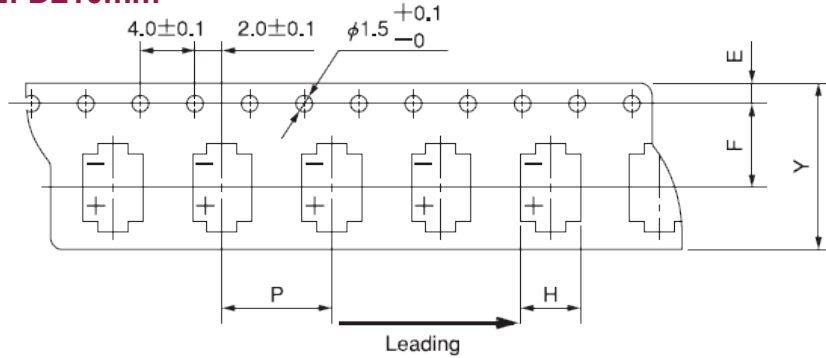

Size (D×L)	Y±0.3	H±0.2	W±0.2	P±0.1	E±0.1	F±0.1	T±0.2
4×5.4	12.0	5.0	5.0	8.0	1.75	5.5	6.0
4×5.8	12.0	5.0	5.0	8.0	1.75	5.5	6.5
4×7.0	12.0	5.0	5.0	8.0	1.75	5.5	7.5
5×5.4	12.0	6.0	6.0	12.0	1.75	5.5	6.0
5×5.8	12.0	6.0	6.0	12.0	1.75	5.5	6.5
5×7.0	12.0	6.0	6.0	12.0	1.75	5.5	7.5
6.3×5.4	16.0	8.7	8.7	12.0	1.75	7.5	6.0
6.3×5.8	16.0	8.7	8.7	12.0	1.75	7.5	6.5
6.3×7.7	16.0	8.7	8.7	12.0	1.75	7.5	8.2
6.3×8.7	16.0	8.7	8.7	12.0	1.75	7.5	9.2
8×6.5	16.0	8.7	8.7	12.0	1.75	7.5	7.2
8×10.5	24.0	8.7	8.7	16.0	1.75	11.5	11.5
8×12.5	24.0	8.7	8.7	16.0	1.75	11.5	13.5
10×7.7	24.0	10.7	10.7	16.0	1.75	11.5	8.5
10×10.5	24.0	10.7	10.7	16.0	1.75	11.5	11.5
10×12.5	24.0	10.7	10.7	16.0	1.75	11.5	13.5
10×13.5	24.0	10.7	10.7	16.0	1.75	11.5	14.5

■ **CARRIER TAPE: D≤12.5mm**

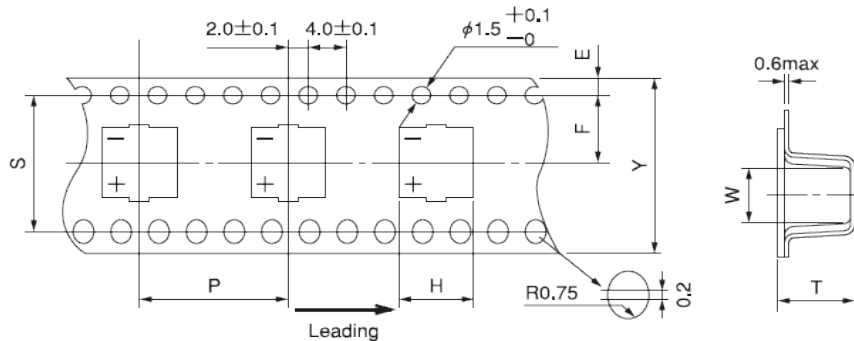

Size (D×L)	Y±0.3	H±0.2	W±0.2	P±0.1	E±0.1	F±0.1	T±0.2	S±0.1
12.5×13.5	12.0	5.0	5.0	8.0	1.75	5.5	6.0	28.5
12.5×16.0	12.0	5.0	5.0	8.0	1.75	5.5	6.5	28.5
16.0×16.5	12.0	5.0	5.0	8.0	1.75	5.5	7.5	40.2

■ **REEL DIMENSIONS AND PACKAGING BOX**

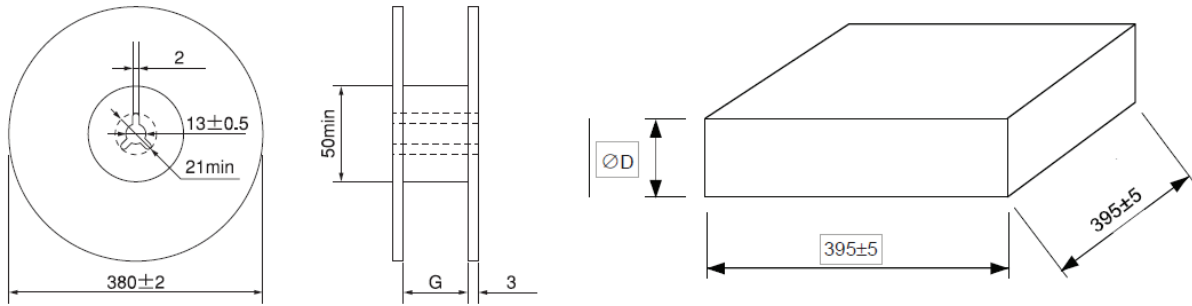

■ **MINIMUM PACKING QUANTITY**

Size (D×L)	Quantity of 1 Reel	Reels / Box	Quantity / Box	G±0.2	D±5
4×5.4	2000	12	24000	14	260
4×5.8	2000	12	24000	14	260
4×7.0	2000	12	24000	14	260
5×5.4	1000	12	12000	14	260
5×5.8	1000	12	12000	14	260
5×7.0	1000	12	12000	14	260
6.3×5.4	1000	10	10000	18	260
6.3×5.8	1000	10	10000	18	260
6.3×7.7	1000	10	10000	18	260
6.3×8.7	900	10	9000	18	260
8×6.5	1000	10	10000	18	260
8×10.5	500	10	5000	26	340
8×12.5	400	10	4000	26	340
10×7.7	500	10	5000	26	340
10×10.5	500	10	5000	26	340
10×12.5	400	10	4000	26	340
10×13.5	400	10	4000	26	340
12.5×13.5	250	6	1500	34	240
12.5×16.0	200	6	1200	34	240
16×16.5	125	5	625	46	260

■ **SURFACE MOUNT TYPE RECOMMENDED LAND PATTERN**

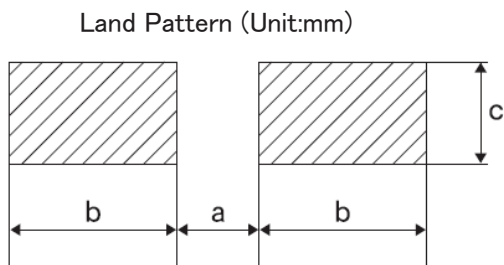

Size	a	b	c
4	1.0	2.6	1.8
5	1.4	3.0	1.8
6.3	1.9	3.5	1.8
8×6.5	3.0(2.2)	4.0	2.5
8	3.0	4.0	2.5
10	4.0	4.5	2.5
12.5	4.0	5.8	3.0
16	6.0	6.8	3.5

■ **REFLOW SOLDERING CONDITION**

1. Thermal condition system such as infrared radiation (IR) or hot blast should be used, vapor phase (VPS) is not recommended.
2. The maximum cycle of reflow soldering is two times. The second cycle must be done after sufficient cooling time for more than one hour to return the temperatures of circuit boards and componenets back to room temperature
3. For lead-free type reflow soldering, please observe proper conditions below:

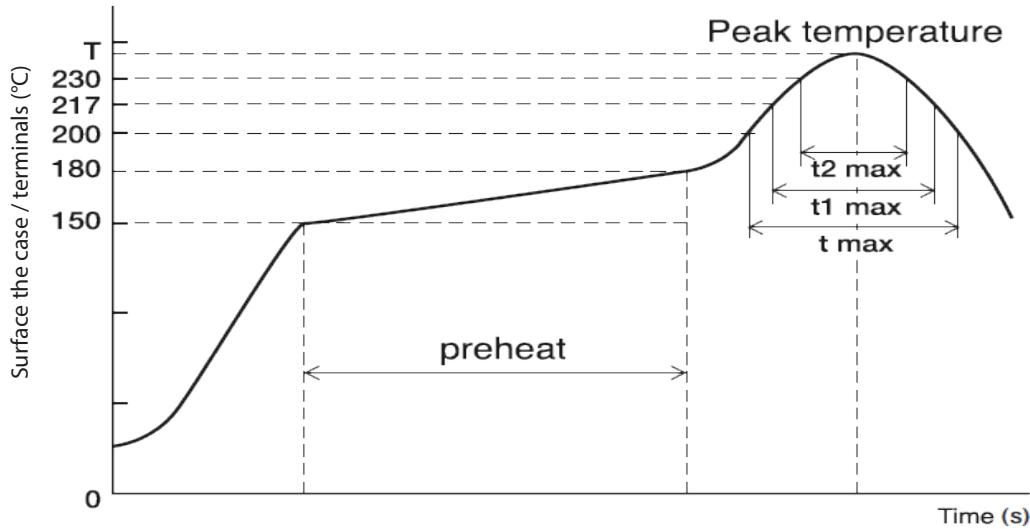

Preheat : 150°C to 180°C within 120 seconds

Voltage (V)	Diameter	200 °C T Max	217 °C T1 Max	230 °C T2 Max	TP55 Max
4 to 63	4 to 6.3	≤ 70 sec.	≤ 60 sec.	≤ 40 sec.	250 °C
	8	≤ 60 sec.	≤ 50 sec.	≤ 30 sec.	245 °C
	10, 12.5	≤ 50 sec.	≤ 40 sec.	≤ 20 sec.	240 °C
	16, 18	≤ 50 sec.	≤ 30 sec.	≤ 15 sec.	235 °C
80 to 100	4 to 6.3	≤ 60 sec.	≤ 50 sec.	≤ 40 sec.	250 °C
	8	≤ 60 sec.	≤ 40 sec.	≤ 30 sec.	240 °C
	10	≤ 50 sec.	≤ 30 sec.	≤ 20 sec.	240 °C
	12.5	≤ 50 sec.	≤ 30 sec.	≤ 20 sec.	235 °C
	16, 18	≤ 45 sec.	≤ 20 sec.	≤ 10 sec.	235 °C

- These devices do not intentionally contain any restricted substances listed in RoHS directive (Cd, Pb, Hg, Cr(VI), PBB, PBDE, DEHP).
- Our products are “articals without any intended release” and are not applicable for registration for REACH article 7.