

■ **FEATURES**

- High frequency operation
- Low forward voltage drop
- High purity, high temperature epoxy encapsulation for enhanced mechanical strength and moisture resistance
- Guard ring for enhanced ruggedness and long term reliability
- Solder dip 275 °C max. 7 s, per JESD 22-B106

■ **TYPICAL APPLICATIONS**

Typical applications are in switching power supplies, converters, freewheeling diodes, and reverse battery protection.

■ **MECHANICAL DATA**

- **Package:** ITO-220AB  
Molding compound meets UL 94 V-0 flammability rating, RoHS-compliant
- **Terminals:** Tin plated leads, solderable per J-STD-002 and JESD22-B102
- **Polarity:** As marked

■ **MAXIMUM RATINGS** (Ta=25°C Unless otherwise specified)

PARAMETER	SYMBOL	UNIT	MBR1045FCTS
Device marking code			MBR1045FCTS
Repetitive Peak Reverse Voltage	V <sub>RRM</sub>	V	45
Average Rectified Output Current @60Hz sine wave, R-load, Tc=100°C	I <sub>O</sub>	A	10
Surge(Non-repetitive)Forward Current @60Hz half sine-wave, 1 cycle, Ta=25°C	I <sub>FSM</sub>	A	100
Current Squared Time @1ms≤t≤8.3ms Tj=25°C,	I <sup>2</sup> t	A <sup>2</sup> s	41
Storage Temperature	T <sub>stg</sub>	°C	-55 ~ +150
Junction Temperature	T <sub>j</sub>	°C	-55 ~ +125

■ **ELECTRICAL CHARACTERISTICS** (Ta=25°C Unless otherwise specified)

PARAMETER	SYMBOL	UNIT	TEST CONDITIONS	MBR1045FCTS
Maximum instantaneous forward voltage drop per diode	V <sub>FM</sub>	V	I <sub>FM</sub> =5.0A	0.65
Maximum DC reverse current at rated DC blocking voltage per diode	I <sub>R RM1</sub>	mA	V <sub>RM</sub> =V <sub>RRM</sub> Ta=25°C	0.2
	I <sub>R RM2</sub>		V <sub>RM</sub> =V <sub>RRM</sub> Ta=100°C	20

■ **THERMAL CHARACTERISTICS** (Ta=25°C Unless otherwise specified)

PARAMETER	SYMBOL	UNIT	MBR1045FCTS
Thermal Resistance Between junction and case	R <sub>θJ-C</sub>	°C/W	4.0

■ **PACKAGING INFORMATION**

PREFERRED P/N	UNIT WEIGHT(g)	MINIMUM PACKAGE(pcs)	INNER BOX QUANTITY(pcs)	OUTER CARTON QUANTITY(pcs)	DELIVERY MODE
MBR1045FCTS	Approximate 1.6	50	1000	5000	Tube

■ **CHARACTERISTICS (TYPICAL)**

**FIG1: I<sub>o</sub> -T<sub>c</sub> Curve**

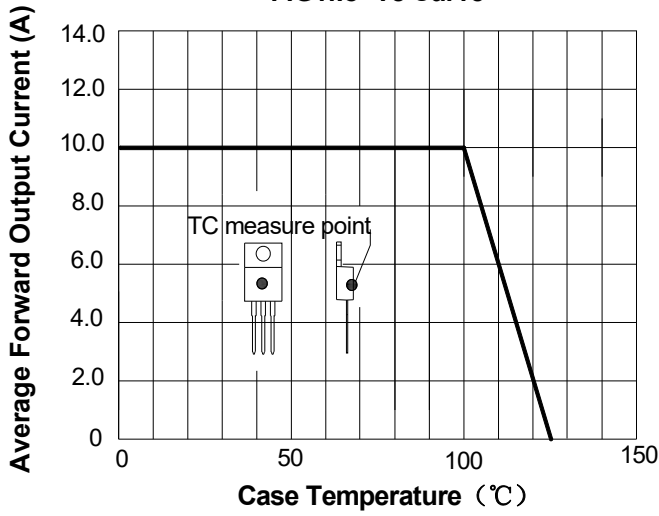

**FIG2: Surge Forward Current Capability**

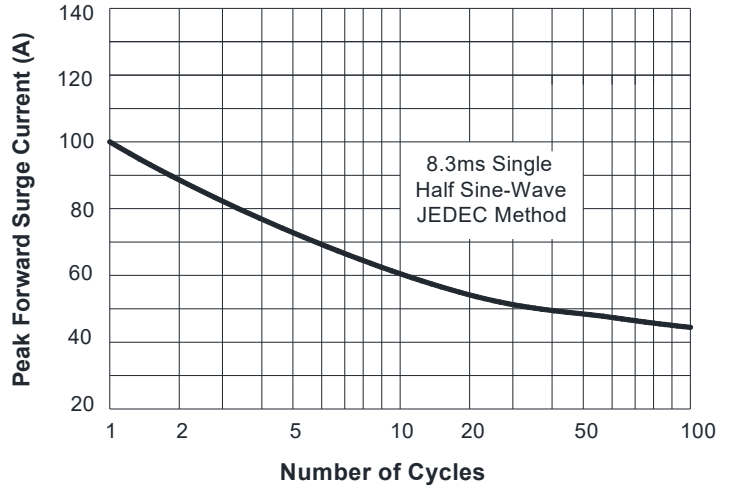

**FIG3: Forward Voltage**

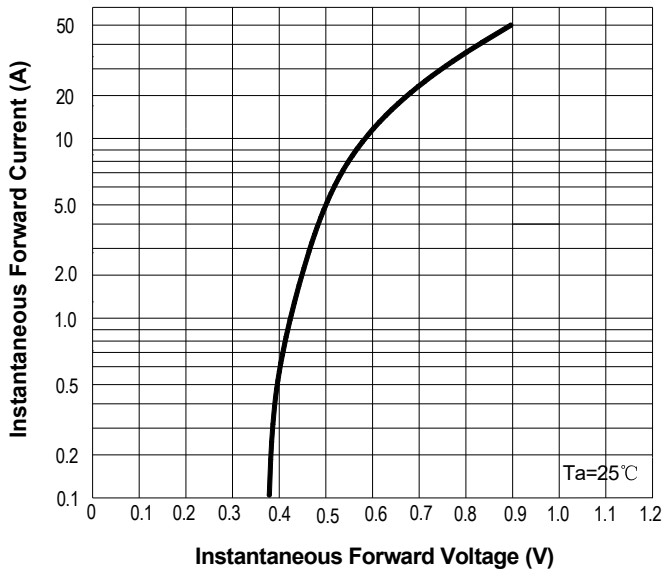

**FIG4: Typical Reverse Characteristics**

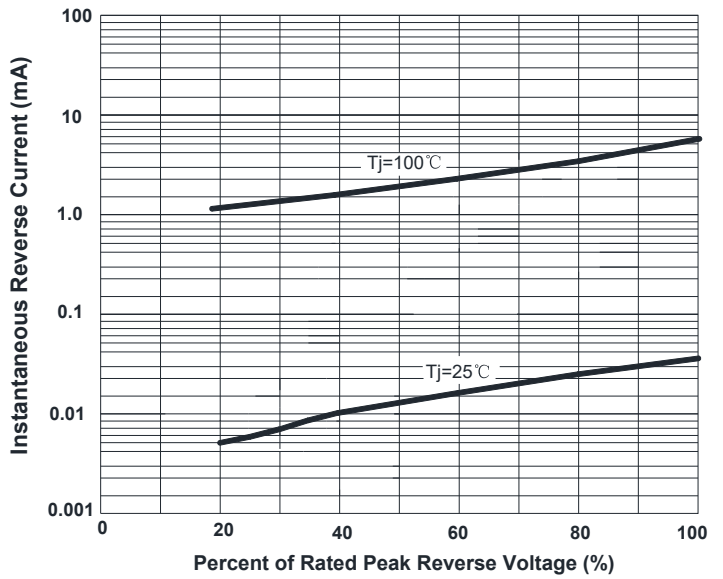

■ **OUTLINE DIMENSIONS**

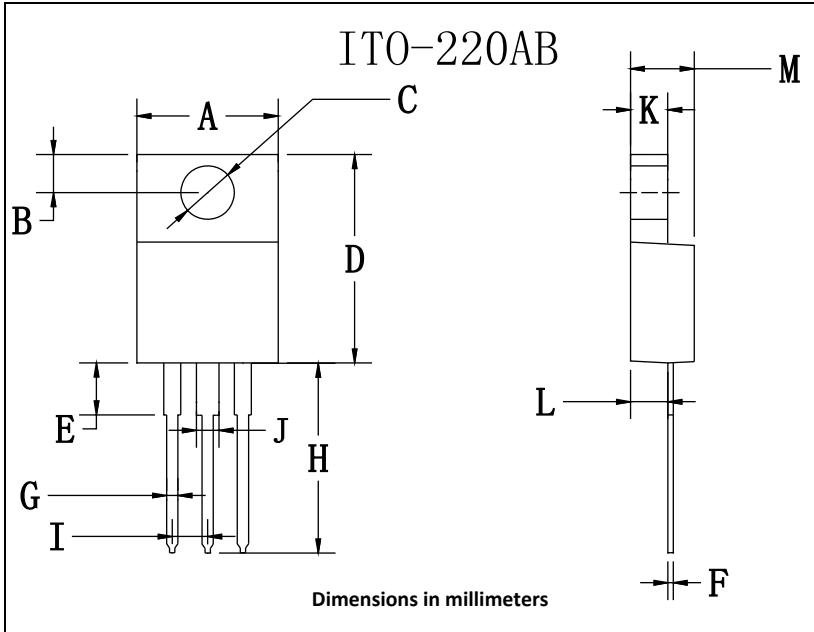

ITO-220AB		
Dim	Min	Max
A	9.7	10.7
B	2.15	3.25
C	2.6	3.8
D	14.4	15.9
E	3.1	4.5
F	0.4	0.8
G	0.4	0.8
H	12.7	14.2
I	1.80	2.95
J	1.4	1.8
K	2.1	3.56
L	2.1	3.2
M	3.9	5.1