

■ FEATURES

- High frequency operation
- Low forward voltage drop
- High purity, high temperature epoxy encapsulation for enhanced mechanical strength and moisture resistance
- Guard ring for enhanced ruggedness and long term reliability
- Solder dip 275 °C max. 7 s, per JESD 22-B106

■ TYPICAL APPLICATIONS

Typical applications are in switching power supplies, converters, freewheeling diodes, and reverse battery protection.

■ MECHANICAL DATA

- **Package:** ITO-220AB
Molding compound meets UL 94 V-0 flammability rating, RoHS-compliant
- **Terminals:** Tin plated leads, solderable per J-STD-002 and JESD22-B102
- **Polarity:** As marked

■ MAXIMUM RATINGS (T_a=25°C Unless otherwise specified)

PARAMETER	SYMBOL	UNIT	MBRL30100FCT
Device marking code			MBRL30100FCT
Repetitive Peak Reverse Voltage	VRRM	V	100
Average Rectified Output Current @60Hz sine wave, R-load, T _a =25°C	I _O	A	30
Surge(Non-repetitive)Forward Current @60Hz half sine-wave, 1 cycle, T _a =25°C	I _{FSM}	A	200
Current Squared Time @1ms<t<8.3ms T _J =25°C	i ² t	A ² s	167
Storage Temperature	T _{stg}	°C	-55 ~ +150
Junction Temperature	T _j	°C	-55 ~ +150

■ ELECTRICAL CHARACTERISTICS (T_a=25°C Unless otherwise specified)

PARAMETER	SYMBOL	UNIT	TEST CONDITIONS	MBRL30100FCT
Maximum instantaneous forward voltage drop per diode	V _{FM}	V	I _{FM} =15.0A	0.72
Maximum DC reverse current at rated DC blocking voltage per diode	I _{RRM1}	mA	V _{RM} =V _{RRM} T _a =25°C	0.1
	I _{RRM2}		V _{RM} =V _{RRM} T _a =100°C	20

■ THERMAL CHARACTERISTICS (T_a=25°C Unless otherwise specified)

PARAMETER	SYMBOL	UNIT	MBRL30100FCT
Thermal Resistance Between junction and case	R _{θj-c}	°C/W	4.0

■ PACKAGING INFORMATION

PREFERRED P/N	UNIT WEIGHT(g)	MINIMUM PACKAGE(pcs)	INNER BOX QUANTITY(pcs)	OUTER CARTON QUANTITY(pcs)	DELIVERY MODE
MBRL30100FCT	Approximate 1.6	50	1000	5000	Tube

■ **CHARACTERISTICS (TYPICAL)**

FIG1: I_o - T_c Curve

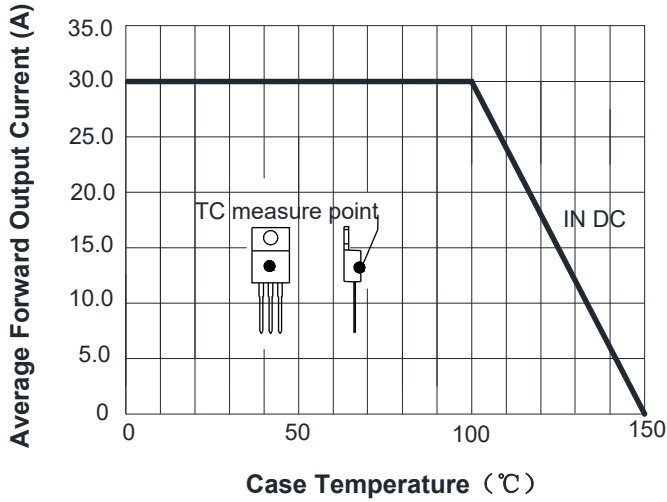

FIG2: Surge Forward Current Capability

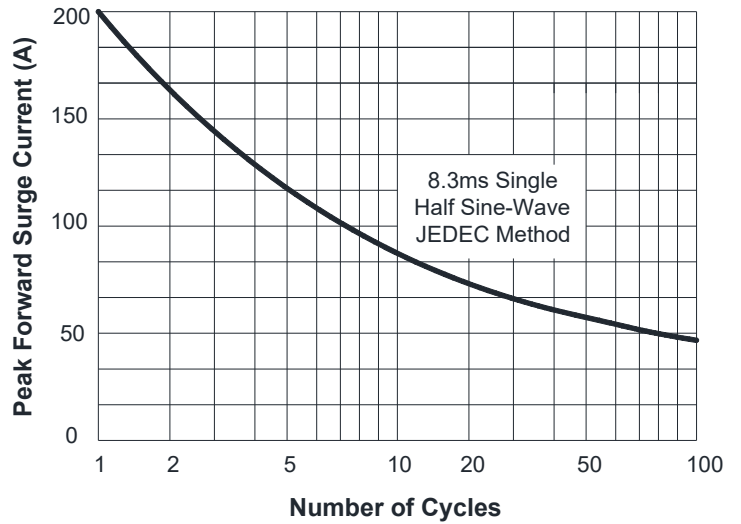

FIG3: Forward Voltage

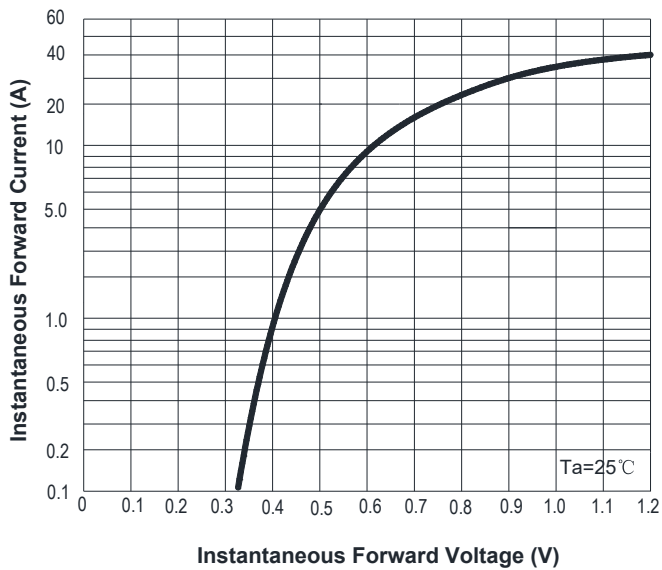
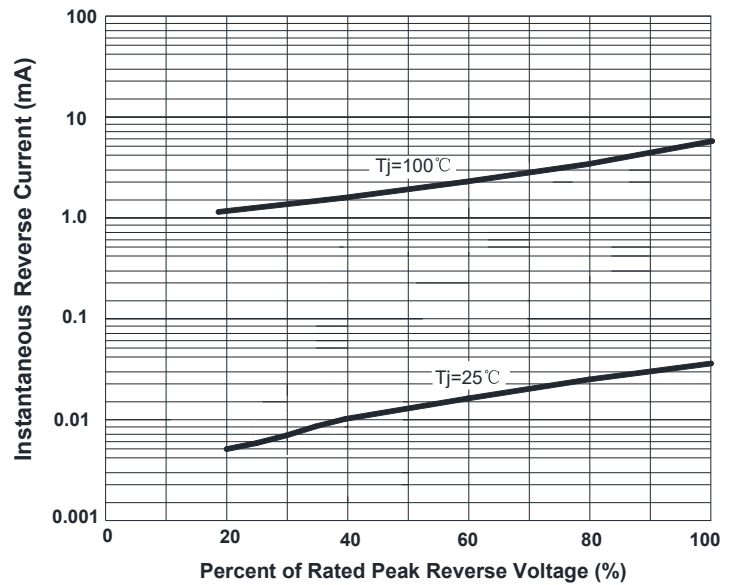
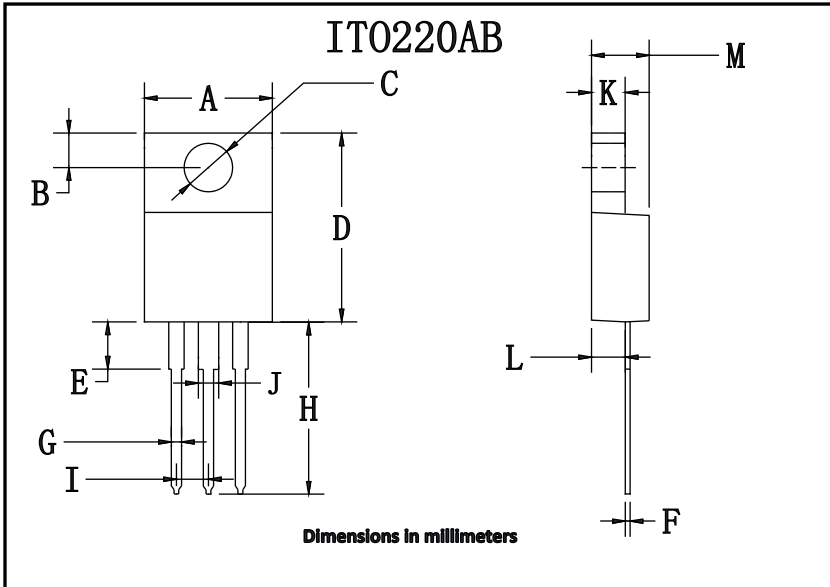

FIG4: Typical Reverse Characteristics



■ **OUTLINE DIMENSIONS**



ITO-220AB		
Dim	Min	Max
A	9.7	10.7
B	2.15	3.25
C	2.6	3.8
D	14.4	15.9
E	3.1	4.5
F	0.4	0.8
G	0.4	0.8
H	12.7	14.2
I	1.80	2.95
J	1.4	1.8
K	2.1	3.56
L	2.1	3.2
M	3.9	5.1