

■ FEATURES

- 105°C, 1000 hours assured.
- Very Low leakage current.
- Use in high temperature industrial equipment.

■ SPECIFICATIONS

Item	Performance										
Operating Temperature Range	-40°C ~ +105°C										
Capacitance Tolerance	± 20% (120Hz, 20°C)										
Leakage Current (at 20°C)	I = 0.002CV or 0.4 (µA) whichever is greater (after 2 minutes). Where, C = rated capacitance in F. V=rated DC working voltage in V.										
Dissipation Factor Tan at 120 Hz, 20°C	Rated Voltage	6.3	10	16	25	35	50	63	100		
	Tan (max)	0.24	0.21	0.16	0.14	0.12	0.10	0.09	0.08		
When the capacitance exceed 1000 F 0.02 shall be added every 1000 F. Impedance ratio shall not exceed the values given in the table below.											
Low Temperature Characteristics (at 120Hz)	Rated Voltage		6.3	10	16	25	35	50	63	100	
	Impedance Ratio	Z(-25°C)/Z(+20°C)	4	3	3	2	2	2	2	2	
		Z(-40°C)/Z(+20°C)	8	6	6	4	4	3	3	3	
Load Life Test (after application of the rated voltage applied for 1000 hours at 105°C)	Test Time	1000 Hrs				Shelf Life Test (at 20°C after rated voltage applied for 1000 hours at 105°C without voltage applied)				Test Time	1000 Hrs
	Capacitance Change	≤ ± 20%								Capacitance Change	≤ ± 20%
	Dissipation Factor	Less than 200% of specified value								Dissipation Factor	Less than 200% of specified value
	Leakage Current	Within specified value								Leakage Current	Within specified value
Ripple Current & Frequency Multipliers	Cap. (µF)	Freq. (Hz)		60(50)	120	500	1K	10K up			
		Under 100		0.75	1.00	1.35	1.55	1.90			
		220 to 1000		0.83	1.00	1.23	1.32	1.45			
		2200 up above		0.90	1.00	1.12	1.10	1.12			
Ripple Current & Temperature Multipliers	Temperature (°C)		Under 50	70	85	105					
	Multipliers		2.20	1.75	1.58	1.00					
Standards	Satisfies Characteristic W of JIS C 5141										

■ DIMENSIONS AND PERMISSIBLE RIPPLE CURRENT

Dimension: D×L(mm) Ripple Current: mA/RMS at 120Hz 105°C

µF	VDC Code	6.3V(0J)		10V(1A)		16V(1C)		25V(1E)		35V(1H)		50V(1H)		63V(1J)		100V(2A)	
		DXL	mA	DXL	mA	DXL	mA	DXL	mA	DXL	mA	DXL	mA	DXL	mA	DXL	mA
0.1	0R1											5 x 11	1.3			5 x 11	2.6
0.22	R22											5 x 11	2.9			5 x 11	5.8
0.33	R33											5 x 11	4.4			5 x 11	8
0.47	R47											5 x 11	7			5 x 11	10
1	010											5 x 11	13			5 x 11	15
2.2	2R2											5 x 11	20			5 x 11	23
3.3	3R3											5 x 11	25			5 x 11	29
4.7	4R7							5 x 11	26	5 x 11	28	5 x 11	30	5 x 11	32	5 x 11	34
10	100					5 x 11	35	5 x 11	38	5 x 11	41	5 x 11	46	5 x 11	50	6.3 x 11	56
22	220			5 x 11	49	5 x 11	54	5 x 11	57	5 x 11	61	5 x 11	68	6.3 x 11	82	8 x 11.5	96
33	330	5 x 11	54	5 x 11	60	5 x 11	64	5 x 11	69	5 x 11	75	6.3 x 11	90	6.3 x 11	100	10 x 12.5	140
47	470	5 x 11	65	5 x 11	70	5 x 11	99	5 x 11	82	6.3 x 11	100	6.3 x 11	110	8 x 11.5	135	10 x 16	180
100	101	5 x 11	95	5 x 11	105	6.3 x 11	125	6.3 x 11	135	8 x 11.5	170	8 x 11.5	180	10 x 12.5	225	13 x 20	320
220	221	6.3 x 11	160	6.3 x 11	175	8 x 11.5	215	8 x 11.5	230	10 x 12.5	300	10 x 16	345	10 x 20	400	16 x 25	570
330	331	6.3 x 11	195	8 x 11.5	245	8 x 11.5	260	10 x 12.5	335	10 x 16	400	10 x 20	460	13 x 20	540	16 x 25	700
470	471	8 x 11.5	270	8 x 11.5	290	10 x 12.5	370	10 x 16	440	10 x 20	520	13 x 20	610	13 x 25	700	16 x 31.5	880
1000	102	10 x 12.5	460	10 x 16	550	10 x 20	640	13 x 20	770	13 x 25	920	16 x 25	1080	16 x 31.5	1210		
2200	222	13 x 20	810	13 x 20	860	13 x 25	1000	16 x 25	1170	16 x 31.5	1340	18 x 35.5	1530				
3300	332	13 x 20	960	13 x 25	1100	16 x 25	1300	16 x 31.5	1460	18 x 35.5	1650						
4700	472	16 x 25	1330	16 x 25	1400	16 x 31.5	1600	18 x 35.5	1780	18 x 40	1900						

■ DIMENSIONS AND PERMISSIBLE RIPPLE CURRENT

Dimension: D×L(mm)

Ripple Current: mA/rms at 100K Hz 105°C

VDC Item μF	6.3V(0J)					10V(1A)					16V(1C)				
	DxL	Impedance (Ω) Max @ 100KHz		Ripple current (mA rms) @ 105°C		DxL	Impedance (Ω) Max @ 100KHz		Ripple current (mA rms) @ 105°C		DxL	Impedance (Ω) Max @ 100KHz		Ripple current (mA rms) @ 105°C	
		20°C	-10°C	120Hz	100KHz		20°C	-10°C	120Hz	100KHz		20°C	-10°C	120Hz	100KHz
33											5 x 11	1.30	3.90	108	154
39											5 x 11	1.30	3.90	108	154
47						5 x 11	2.10	5.50	78	111	6.3 x 11	0.60	1.80	182	260
56						5 x 11	1.90	4.80	85	121	6.3 x 11	0.60	1.80	182	260
68						5 x 11	1.30	3.90	108	154	6.3 x 11	0.60	1.80	182	260
100	5 x 11	1.30	3.90	108	154	6.3 x 11	0.60	1.80	182	260	6.3 x 11	0.60	1.80	182	260
220	6.3 x 11	0.60	1.80	182	260	8 x 11.5	0.33	0.99	280	400	8 x 11.5	0.33	0.99	320	400
330	8 x 11.5	0.33	0.88	280	400	8 x 11.5	0.33	0.99	280	400	10 x 12.5	0.25	0.75	360	510
390	8 x 11.5	0.33	0.88	320	400	10 x 12.5	0.27	0.70	410	510	10 x 16	0.19	0.57	510	635
470	10 x 12.5	0.25	0.75	410	510	10 x 12.5	0.25	0.75	410	510	10 x 16	0.19	0.57	510	635
560	10 x 12.5	0.25	0.75	410	510	10 x 16	0.19	0.57	510	635	10 x 20	0.14	0.42	775	860
680	10 x 16	0.19	0.57	510	635	10 x 16	0.19	0.57	510	635	10 x 20	0.14	0.42	775	860
1000	10 x 20	0.14	0.42	690	860	10 x 20	0.14	0.37	690	860	12.5 x 20	0.085	0.26	1000	1250
1200	10 x 20	0.14	0.42	775	860	10 x 25	0.12	0.30	930	1030	12.5 x 20	0.085	0.26	1125	1250
2200	12.5 x 20	0.085	0.26	1125	1250	12.5 x 25	0.070	0.21	1200	1355	12.5 x 25	0.070	0.21	1200	1355
3300	12.5 x 25	0.070	0.21	1200	1355	12.5 x 25	0.070	0.21	1200	1355	16 x 31.5	0.048	0.14	1830	2030
4700	16 x 25	0.060	0.18	1595	1770	16 x 31.5	0.048	0.14	1830	2030	16 x 35.5	0.044	0.13	2065	2295

■ LEAD SPACING AND DIAMETER SPECIFICATIONS

D	5	6.3	8	10	13	16	18
P	2.0	2.5	3.5	5.0	5.0	7.5	7.5
d	0.5		0.6		0.8		
α	1.0			1.5			
β	0.5						

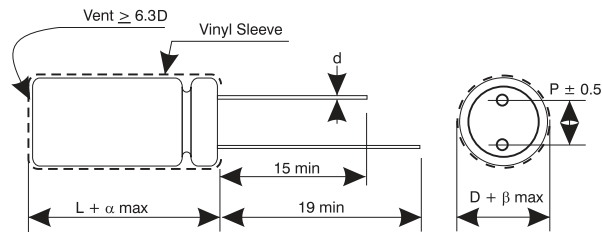

■ HOW TO MAKE A PART NUMBER

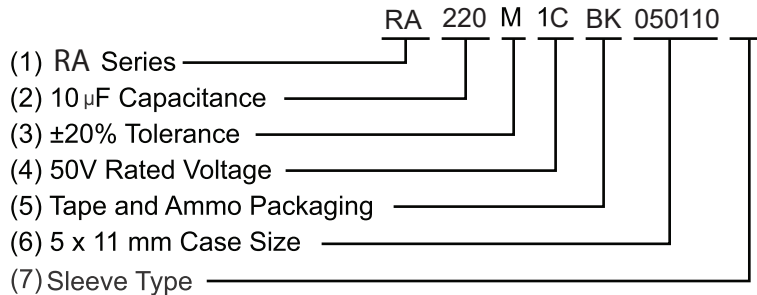

1. Series: RA

2. Capacitance: Rated capacitance in μF is represented by a three digit number. The first two digits are the significant figures of the nominal capacitance and the third digit indicates the number of zeros following these figures. The decimal point is represented by the capital letter R. Please refer to the following example.

μF	0.1	0.47	1	4.7	10	47	100	470	1000	4700	10000
Part Number	0R1	R47	010	4R7	100	470	101	471	102	472	103

3. Tolerance: (20% IS Typical)

Code	K	M	T	W
Tolerance	$\pm 10\%$	$\pm 20\%$	$\pm 50\% / -10\%$	$\pm 100\% / -10\%$

4. Rated Voltage: Voltage in volts (V) is represented by a two digit code showing the rated working voltage indicated as follows:

Voltage (WV)	6.3	10	16	25	35	40	50	63	80	100	160	200	250	350	400	450
Code	0J	1A	1C	1E	1V	1G	1H	1J	1K	2A	2C	2D	2E	2V	2G	2W

5. Lead Forming & Package

Code	Lead Description	Packaging
BC	Bending Cut	Bulk Packing
BK	Straight Lead	Bulk Packing
CC	Lead Cutting	Bulk Packing
FC	Lead Forming & Cutting	Bulk Packing
SD	Cathode Lead Beading	Bulk Packing
SF	Snap-in, Forming & Cutting	Bulk Packing
SA	Straight Lead	Tape & Ammo
TA	Lead Forming	Tape & Ammo
SR	Straight Lead	Tape & Reel
TR	Lead Forming	Tape & Reel

6. Can Size

Diameter (mm)x10 & Length (mm)x10. Can Size 063110, represents 6.3mm diameter by 11mm length.

7. Sleeve Type* = (Omit) PVC Sleeve

P = PET Sleeve

*Note: All standard RFE Aluminum Electrolytic Capacitors are Lead (Pb) free and RoHS compliant. PET sleeve is available for those companies that also require PVC free product.

LEADED TAPING & PACKAGING SPECIFICATIONS Taping Specification for Radial Lead Type

Fig. 1

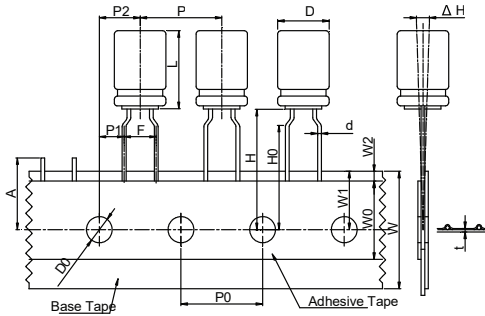

Fig. 2

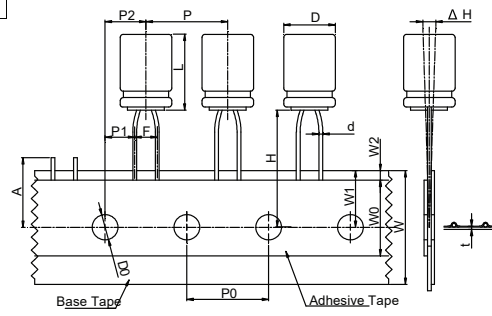

Fig. 3

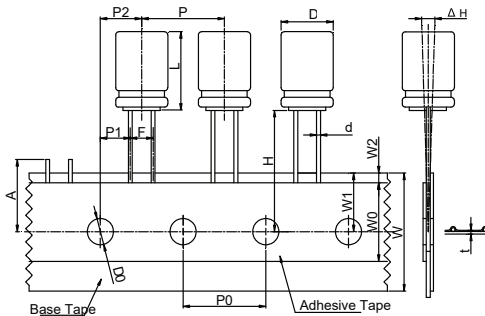
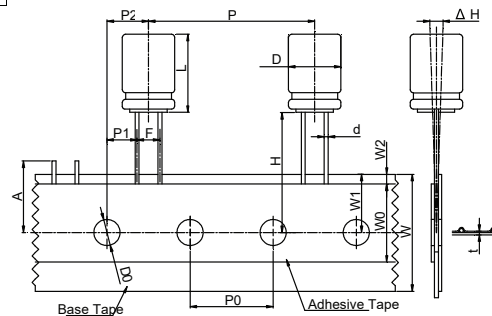
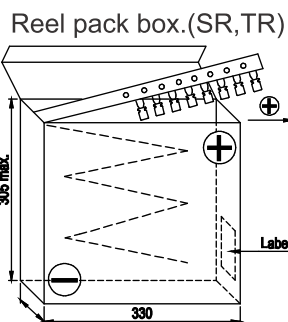

Fig. 4



Packing	TA, TR (Fig. 1)								SA, SR (Fig. 2, 3, 4)											
	L ≤ 7mm				L ≥ 7mm				L ≤ 7mm					L ≥ 7mm						
Symbol	3	4	5	6.3	8	5	6.3	8	3	4	5	6.3	8	5	6.3	8	Tol.	10	13	Tol.
d	0.4	0.45	0.5	0.5	0.5	0.5	0.5	0.6	0.4	0.45	0.45	0.45	0.45	0.5	0.5	0.6	± 0.05	0.6	0.6	± 0.05
F	5.0	5.0	5.0	5.0	5.0	5.0	5.0	5.0	2.5	2.5	2.5	2.5	3.5	2.5	2.5	3.5	-0.2/+0.8	5.0	5.0	-0.2/+0.8
P	12.7	12.7	12.7	12.7	12.7	12.7	12.7	12.7	12.7	12.7	12.7	12.7	12.7	12.7	12.7	12.7	± 1.0	12.7	25.4	± 1.0
P0	12.7	12.7	12.7	12.7	12.7	12.7	12.7	12.7	12.7	12.7	12.7	12.7	12.7	12.7	12.7	12.7	± 0.2	12.7	12.7	± 0.30
P2	6.35	6.35	6.35	6.35	6.35	6.35	6.35	6.35	6.35	6.35	6.35	6.35	6.35	6.35	6.35	6.35	± 1.0	6.35	6.35	± 1.3
P1	3.85	3.85	3.85	3.85	3.85	3.85	3.85	3.85	5.1	5.1	5.1	5.1	4.6	5.1	5.1	4.6	± 0.5	3.85	3.85	± 0.7
H	17.5	17.5	17.5	17.5	17.5	18.5	18.5	20.0	17.5	17.5	17.5	17.5	17.5	18.5	18.5	18.5	± 0.75	18.5	18.5	± 0.75
H0	16.0	16.0	16.0	16.0	16.0	16.0	16.0	--	--	--	--	--	--	--	--	--	± 0.5	--	--	± 0.5
W	18.0	18.0	18.0	18.0	18.0	18.0	18.0	18.0	18.0	18.0	18.0	18.0	18.0	18.0	18.0	18.0	± 0.5	18.0	18.0	± 0.5
W0	12.0	12.0	12.0	12.0	12.0	12.0	12.0	12.0	12.0	12.0	12.0	12.0	12.0	12.0	12.0	12.0	Min	12.0	12.0	Min.
W1	9.0	9.0	9.0	9.0	9.0	9.0	9.0	9.0	9.0	9.0	9.0	9.0	9.0	9.0	9.0	9.0	± 0.5	9.0	9.0	± 0.5
W2	1.5	1.5	1.5	1.5	1.5	1.5	1.5	1.5	1.5	1.5	1.5	1.5	1.5	1.5	1.5	1.5	Max.	1.5	1.5	Max.
D0	4.0	4.0	4.0	4.0	4.0	4.0	4.0	4.0	4.0	4.0	4.0	4.0	4.0	4.0	4.0	4.0	± 0.2	4.0	4.0	± 0.2
t	0.7	0.7	0.7	0.7	0.7	0.7	0.7	0.7	0.7	0.7	0.7	0.7	0.7	0.7	0.7	0.7	± 0.2	0.7	0.7	± 0.2
ΔH	0	0	0	0	0	0	0	0	0	0	0	0	0	0	0	0	± 1.0	0	0	± 1.0
ε	1.0	1.0	1.0	1.0	1.0	1.0	1.0	1.0	1.0	1.0	1.0	1.0	1.0	1.0	1.0	1.0	Max.	1.0	1.0	Max.
A	11	11	11	11	11	11	11	11	11	11	11	11	11	11	11	11	Max.	11	11	Max.
Fig. No.	1	1	1	1	1	1	1	1	2	2	2	3	3	2	3	3		3	3,4	

Ammo pack box.(SA,TA)
10 Boxes per carton



Reel pack box.(SR,TR)

Packaging Quantity

D	3	4	5	6.3	8	10	13
TA, SA	3000	2000	2000	2000	1000	500	250
TR, SR	3000	1500	1200	1000	800	500	500

NOTES:

- The above quantities are typical. Quantities may vary.
- The component will be oriented on the tape so that the positive lead is leading or the negative lead is leading, depending on the customer's request

■ **RADIAL FORMING**

Lead Forming & Cutting Specifications for Radial Type (Unit: mm)

Forming Method	Code	Shape	Dimensions																																																																																
Forming Cut (4 ~ 8)	FC		<table border="1"> <thead> <tr> <th>D x L</th> <th>d</th> <th>F</th> <th>F'</th> <th>H</th> </tr> </thead> <tbody> <tr><td>3 x 5</td><td>0.40</td><td>1.0</td><td>5.0</td><td>5.0</td></tr> <tr><td>4 x 5</td><td>0.45</td><td>1.5</td><td>5.0</td><td>5.0</td></tr> <tr><td>5 x 5</td><td>0.45</td><td>2.0</td><td>5.0</td><td>5.0</td></tr> <tr><td>6.3 ~ 8 x 5</td><td>0.45</td><td>2.5</td><td>5.0</td><td>5.0</td></tr> <tr><td>4 x 7</td><td>0.45</td><td>1.5</td><td>5.0</td><td>5.0</td></tr> <tr><td>5 x 7 ~ 11</td><td>0.5</td><td>2.0</td><td>5.0</td><td>5.0</td></tr> <tr><td>6 x 7 ~ 15</td><td>0.5</td><td>2.5</td><td>5.0</td><td>5.0</td></tr> <tr><td>8 x 7 ~ 9</td><td>0.5</td><td>3.5</td><td>5.0</td><td>5.0</td></tr> <tr><td>8 x 11.5 ~ 20</td><td>0.6</td><td>3.5</td><td>5.0</td><td>5.0</td></tr> <tr><td>10</td><td>0.6</td><td>5.0</td><td>-</td><td>4.5</td></tr> <tr><td>12.5</td><td>0.6</td><td>5.0</td><td>-</td><td>4.5</td></tr> <tr><td>16</td><td>0.8</td><td>7.5</td><td>-</td><td>4.5</td></tr> <tr><td>18</td><td>0.8</td><td>7.5</td><td>-</td><td>4.5</td></tr> <tr><td>22</td><td>1.0</td><td>10.0</td><td>-</td><td>4.5</td></tr> <tr><td>25</td><td>1.0</td><td>12.5</td><td>-</td><td>4.5</td></tr> </tbody> </table>	D x L	d	F	F'	H	3 x 5	0.40	1.0	5.0	5.0	4 x 5	0.45	1.5	5.0	5.0	5 x 5	0.45	2.0	5.0	5.0	6.3 ~ 8 x 5	0.45	2.5	5.0	5.0	4 x 7	0.45	1.5	5.0	5.0	5 x 7 ~ 11	0.5	2.0	5.0	5.0	6 x 7 ~ 15	0.5	2.5	5.0	5.0	8 x 7 ~ 9	0.5	3.5	5.0	5.0	8 x 11.5 ~ 20	0.6	3.5	5.0	5.0	10	0.6	5.0	-	4.5	12.5	0.6	5.0	-	4.5	16	0.8	7.5	-	4.5	18	0.8	7.5	-	4.5	22	1.0	10.0	-	4.5	25	1.0	12.5	-	4.5
D x L	d	F	F'	H																																																																															
3 x 5	0.40	1.0	5.0	5.0																																																																															
4 x 5	0.45	1.5	5.0	5.0																																																																															
5 x 5	0.45	2.0	5.0	5.0																																																																															
6.3 ~ 8 x 5	0.45	2.5	5.0	5.0																																																																															
4 x 7	0.45	1.5	5.0	5.0																																																																															
5 x 7 ~ 11	0.5	2.0	5.0	5.0																																																																															
6 x 7 ~ 15	0.5	2.5	5.0	5.0																																																																															
8 x 7 ~ 9	0.5	3.5	5.0	5.0																																																																															
8 x 11.5 ~ 20	0.6	3.5	5.0	5.0																																																																															
10	0.6	5.0	-	4.5																																																																															
12.5	0.6	5.0	-	4.5																																																																															
16	0.8	7.5	-	4.5																																																																															
18	0.8	7.5	-	4.5																																																																															
22	1.0	10.0	-	4.5																																																																															
25	1.0	12.5	-	4.5																																																																															
Cut (3 ~ 25)	CC																																																																																		
Bending Cut (5 ~ 25)	BC		<table border="1"> <thead> <tr> <th>D x L</th> <th>d</th> <th>F±0.5</th> </tr> </thead> <tbody> <tr><td>5 X 11</td><td>0.5</td><td>2.0</td></tr> <tr><td>6.3 X 11 ~ 15</td><td>0.5</td><td>2.5</td></tr> <tr><td>8 X 11.5 ~ 20</td><td>0.6</td><td>3.5</td></tr> <tr><td>10</td><td>0.6</td><td>5.0</td></tr> <tr><td>12.5</td><td>0.6</td><td>5.0</td></tr> <tr><td>16</td><td>0.8</td><td>7.5</td></tr> <tr><td>18</td><td>0.8</td><td>7.5</td></tr> <tr><td>22</td><td>1.0</td><td>10.0</td></tr> <tr><td>25</td><td>1.0</td><td>12.5</td></tr> </tbody> </table>	D x L	d	F±0.5	5 X 11	0.5	2.0	6.3 X 11 ~ 15	0.5	2.5	8 X 11.5 ~ 20	0.6	3.5	10	0.6	5.0	12.5	0.6	5.0	16	0.8	7.5	18	0.8	7.5	22	1.0	10.0	25	1.0	12.5																																																		
D x L	d	F±0.5																																																																																	
5 X 11	0.5	2.0																																																																																	
6.3 X 11 ~ 15	0.5	2.5																																																																																	
8 X 11.5 ~ 20	0.6	3.5																																																																																	
10	0.6	5.0																																																																																	
12.5	0.6	5.0																																																																																	
16	0.8	7.5																																																																																	
18	0.8	7.5																																																																																	
22	1.0	10.0																																																																																	
25	1.0	12.5																																																																																	
(10 ~ 25)	SD																																																																																		