

FEATURES

- UL recognition, file #E313149
- Glass passivated chip junction
- High surge current capability
- Solder dip 275 °C max. 7 s, per JESD 22-B106

TYPICAL APPLICATIONS

General purpose use in AC/DC bridge full wave rectification for SMPS, lighting ballast, adapter, battery charger, home appliances, office equipment, and telecommunication applications.

MECHANICAL DATA

- **Package:** DB
Molding compound meets UL 94 V-0 flammability rating, RoHS-compliant, Halogen free
- **Terminals:** Tin plated leads, solderable per J-STD-002 and JESD22-B102
- **Polarity:** As marked on body

MAXIMUM RATINGS (T_a=25°C Unless otherwise specified)

PARAMETER	SYMBOL	UNIT	DB151	DB152	DB153	DB154	DB155	DB156	DB157
Device marking code			DB151	DB152	DB153	DB154	DB155	DB156	DB157
Maximum Repetitive Peak Reverse Voltage	VRRM	V	50	100	200	400	600	800	1000
Maximum RMS Voltage	VRMS	V	35	70	140	280	420	560	700
Maximum DC blocking Voltage	VDC	V	50	100	200	400	600	800	1000
Average rectified output current @60Hz sine wave, R-load, T _c =126°C	I _O	A	1.5						
Forward Surge Current (Non-repetitive) @60Hz Half-sine wave, 1 cycle, T _j =25°C	I _{FSM}	A	60						
Forward Surge Current (Non-repetitive) @1ms, square wave, 1 cycle, T _j =25°C			120						
Current squared time @1ms ≤ t ≤ 8.3ms T _j =25°C, Rating of per diode	I ² t	A ² s	14.9						
Storage temperature	T _{stg}	°C	-55 ~ +150						
Junction temperature	T _j	°C	-55 ~ +150						

ELECTRICAL CHARACTERISTICS (T_a=25°C Unless otherwise specified)

PARAMETER	SYMBOL	UNIT	TEST CONDITIONS	DB151	DB152	DB153	DB154	DB155	DB156	DB157
Maximum instantaneous forward voltage drop per diode	V _F	V	I _F M=0.7A	1.0						
Maximum DC reverse current at rated DC blocking voltage per diode	I _R	μA	T _j =25°C	5						
			T _j =125°C	100						
Typical junction capacitance	C _j	pF	Measured at 1MHz and Applied Reverse Voltage of 4.0 V.D.C	19						

■ **THERMAL CHARACTERISTICS** ($T_a=25^{\circ}\text{C}$ Unless otherwise specified)

PARAMETER	SYMBOL	UNIT	DB151	DB152	DB153	DB154	DB155	DB156	DB157
Typical Thermal Resistance	R θ J-A	$^{\circ}\text{C}/\text{W}$	40.0						
	R θ J-L		15.0						
	R θ J-C		8.0						

Note: Device mounted on P.C.B with 35mm*25mm*1.7mm

■ **PACKAGING INFORMATION**

PREFERRED P/N	PACKING CODE	UNIT WEIGHT(g)	MINIIMUM PACKAGE(pcs)	INNER BOX QUANTITY(pcs)	OUTER CARTON QUANTITY(pcs)	DELIVERY MODE
DB151 ~ DB157	B1	Approximate 0.39	50	2500	10000	Tube

■ **CHARACTERISTICS (TYPICAL)**

FIG1: I_o - T_c Curve

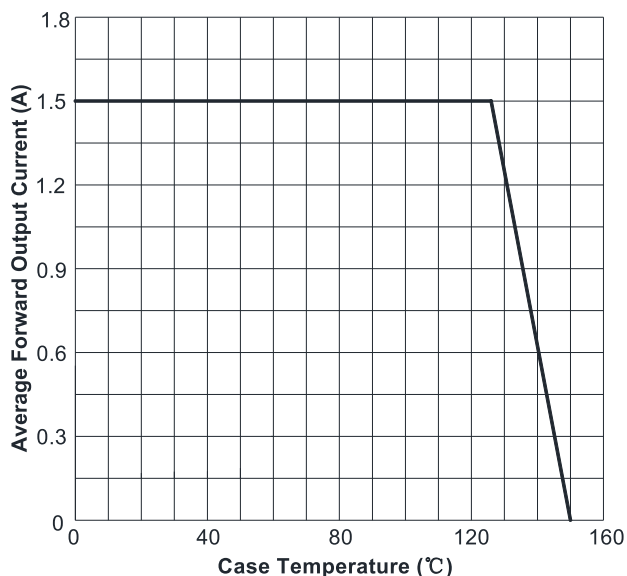

FIG2: Surge Forward Current Capability

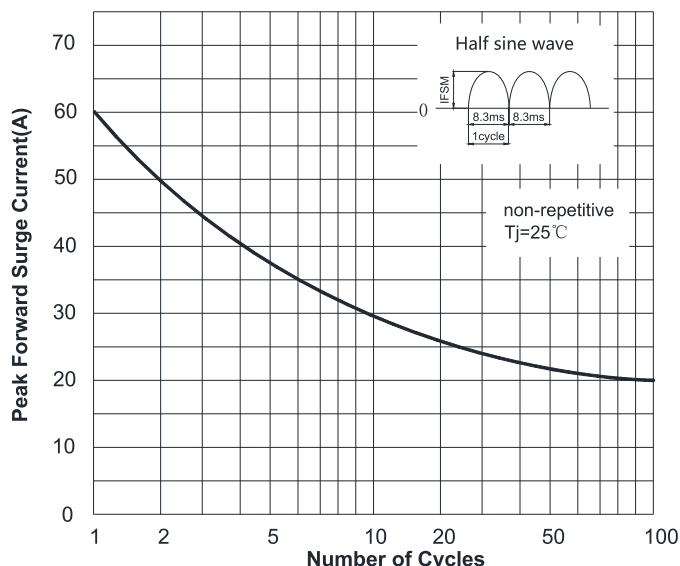

FIG3: Typical Forward Voltage

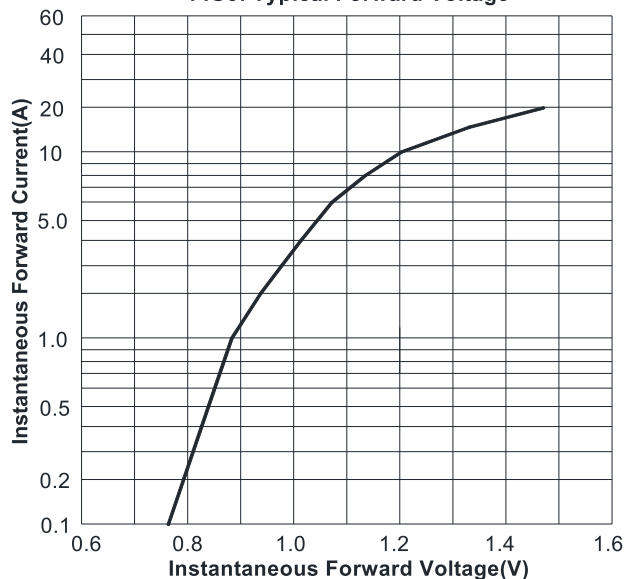
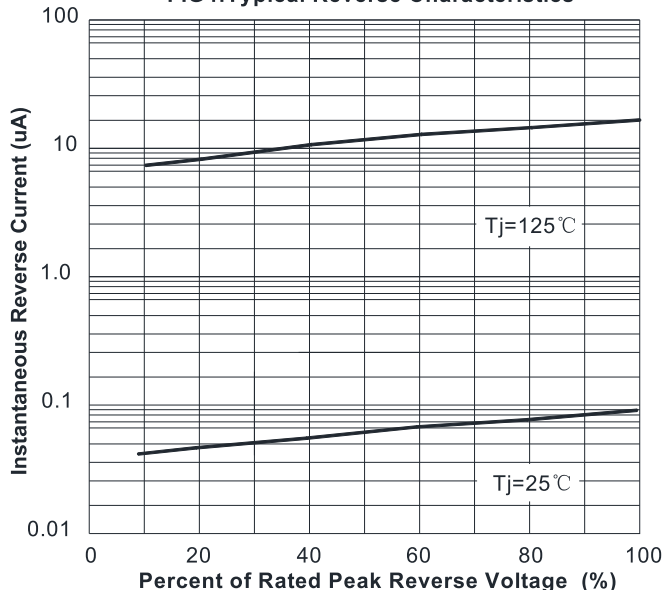
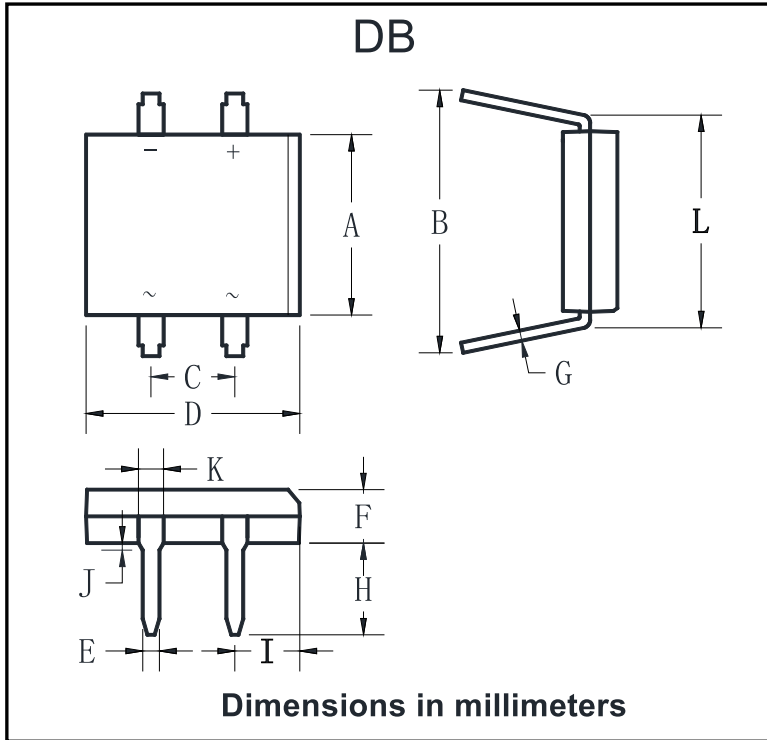

FIG4: Typical Reverse Characteristics



■ **OUTLINE DIMENSIONS**



DB		
Dim	Min	Max
A	6.20	6.50
B	7.60	8.90
C	5.00	5.20
D	8.13	8.51
E	0.46	0.58
F	2.80	3.30
G	0.22	0.33
H	3.81	4.69
I	1.39	1.90
J	1.27	2.03
K	0.89	1.14
L	7.24	8.00