

INTRODUCTION

MES Series are constructed with metalized polyester film dielectric, copperplated lead and epoxy resin powder coating. They are suitable for blocking, coupling, decoupling, filtering, bypass timing circuit and ideal for use in telecommunication equipment, data processing equipment, industrial instrument, automatic control systems and other general electronic equipment.

FEATURES

- High moisture resistance
- Good solderability
- Non-inductive construction
- Self-healing property
- Miniature Size
- Standard 5mm lead spacing

SPECIFICATIONS

Item	Performance
Operating Temp. Range	-40°C ~ 125°C (VR Derates 1.25% per °C over 105°C)
Capacitance Range	0.001µF ~ 1.2µF
Capacitance Tolerance	± 5% (J), 10% (K), +20% (M)
Rated Voltage VR 85°C	50/63Vdc, 100Vdc, 250Vdc, 400Vdc, 630Vdc
Dissipation Factor	1.0%(0.01)max @ 1Khz, 25°C
Insulation Resistance	VR ≤ 100Vdc ≥ 15000MΩ (C ≤ 0.33µF) ≥ 5000MΩ x µF (C > 0.33µF) VR ≤ 100Vdc ≥ 30000MΩ (C ≤ 0.33µF) ≥ 10000MΩ x µF (C > 0.33µF)

PART NUMBER EXAMPLE

MES 104 K 2A 050 B 250 S**

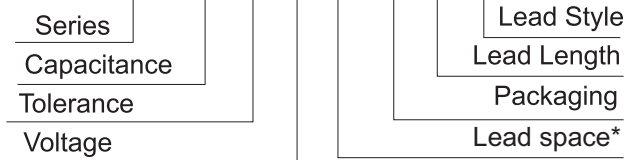

* Leadspace is straight lead non-formed original leadspace.

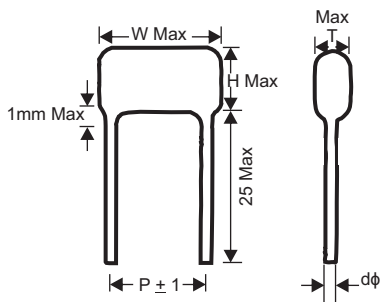

CAPACITANCE CODE

µF	0.01	0.047	0.1	0.47	1.0
pF	10000	47000	100000	470000	-
Code	103	473	104	474	105

RATED VOLTAGE

WV	50	63	100	250	400	630
Code	1H	1J	2A	2E	2G	2J

PACKAGING

Method	Bulk	Ammo	Reel
Code	B	A	R

RADIAL LEAD SPACING

* Leadspace is straight lead non-formed original leadspace.

mm	5
Code	050

LEAD LENGTH FROM SEATING PLANE (Bulk Pack)

mm	5	10	15	20	25
Code	050	100	150	200	250

TOLERANCE

Code	Tolerance
J	± 5%
K	± 10%
M	± 20%

LEAD STYLE EXAMPLES

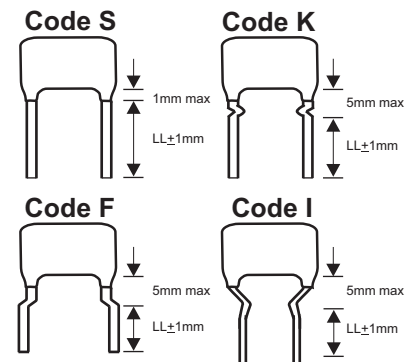

Typical length (LL) is 20 mm for straight lead, bulk pack

TAPE CODE (Lead spacing of tape)

Spacing	5mm
Packing	A or R
Code	RT1 (See Diagram)

LEAD STYLE

Code	Style
S	Straight
K	Kink-In (Stand Off)
F	Form Out

** For Bulk packaging with formed leads, add an additional 3 digit lead spacing code at end of part number.

MAXIMUM DIMENSIONS (mm)

(μF)	W. V. code	50 / 63VDC (1H/1J)					100VDC (2A)					250VDC (2E)					400VDC (2G)					630VDC (2J)									
		W	H	T	P	d	W	H	T	P	d	W	H	T	P	d	W	H	T	P	d	W	H	T	P	d					
0.001	102	6.5	6.5	3.5	5	0.5	10	6.5	6.5	3.5	5	0.5	15	6.5	6.5	3.5	5	0.5	50	6.5	6.5	3.5	5	0.5	50	6.5	6.5	3.5	5	0.5	50
0.002	122	6.5	6.5	3.5	5	0.5	10	6.5	6.5	3.5	5	0.5	15	6.5	6.5	3.5	5	0.5	50	6.5	6.5	3.5	5	0.5	50	6.5	6.5	3.5	5	0.5	50
0.003	332	6.5	6.5	3.5	5	0.5	10	6.5	6.5	3.5	5	0.5	15	6.5	6.5	3.5	5	0.5	50	6.5	6.5	3.5	5	0.5	50	6.5	6.5	3.5	5	0.5	50
0.005	472	6.5	6.5	3.5	5	0.5	10	6.5	6.5	3.5	5	0.5	15	6.5	6.5	3.5	5	0.5	50	6.5	6.5	3.5	5	0.5	50	6.5	6.5	3.5	5	0.5	50
0.006	562	6.5	6.5	3.5	5	0.5	10	6.5	6.5	3.5	5	0.5	15	6.5	6.5	3.5	5	0.5	50	6.5	6.5	3.5	5	0.5	50						
0.007	682	6.5	6.5	3.5	5	0.5	10	6.5	6.5	3.5	5	0.5	15	6.5	6.5	3.5	5	0.5	50	6.5	6.5	3.5	5	0.5	50						
0.008	822	6.5	6.5	3.5	5	0.5	10	6.5	6.5	3.5	5	0.5	15	6.5	6.5	3.5	5	0.5	50	6.5	6.5	3.5	5	0.5	50						
0.010	103	6.5	6.5	4.0	5	0.5	25	6.5	6.5	4.0	5	0.5	25	6.5	6.5	3.5	5	0.5	50	6.5	6.5	3.5	5	0.5	50						
0.012	123	6.5	6.5	4.0	5	0.5	25	6.5	6.5	4.0	5	0.5	25	6.5	6.5	3.5	5	0.5	50												
0.015	153	6.5	6.5	4.0	5	0.5	25	6.5	6.5	4.0	5	0.5	25	6.5	6.5	3.5	5	0.5	50												
0.018	183	6.5	6.5	4.0	5	0.5	25	6.5	6.5	4.0	5	0.5	25	6.5	6.5	3.5	5	0.5	50												
0.022	223	6.5	6.5	4.0	5	0.5	25	6.5	6.5	4.0	5	0.5	25	6.5	6.5	3.5	5	0.5	50												
0.027	273	6.5	6.5	4.0	5	0.5	25	6.5	6.5	4.0	5	0.5	25	7.5	9.5	3.5	5	0.5	30												
0.033	333	6.5	6.5	4.0	5	0.5	25	6.5	6.5	4.0	5	0.5	25	7.5	9.5	4.5	5	0.5	30												
0.039	393	6.5	6.5	4.0	5	0.5	25	6.5	6.5	4.0	5	0.5	25	7.5	9.5	4.5	5	0.5	30												
0.047	473	6.5	6.5	4.0	5	0.5	25	6.5	6.5	4.0	5	0.5	25	7.5	9.5	4.5	5	0.5	30	7.5	10	6	5	0.6	30						
0.056	563	6.5	6.5	4.0	5	0.5	25	6.5	6.5	4.0	5	0.5	25	7.5	9.5	4.5	5	0.5	30												
0.068	683	6.5	6.5	4.0	5	0.5	25	6.5	6.5	4.0	5	0.5	25	7.5	9.5	4.5	5	0.5	30												
0.082	823	6.5	6.5	4.0	5	0.5	25	6.5	6.5	4.0	5	0.5	25	7.5	9.5	4.5	5	0.5	30												
0.1	104	6.5	6.5	4.5	5	0.5	25	6.5	6.5	4.5	5	0.5	25	7.5	9.5	4.5	5	0.5	30												
0.12	124	6.5	6.5	4.5	5	0.5	25	6.5	6.5	4.5	5	0.5	25	7.5	10	5.0	5	0.5	30												
0.15	154	6.5	6.5	4.5	5	0.5	25	6.5	6.5	4.5	5	0.5	25	7.5	10	5.0	5	0.5	30												
0.18	184	6.5	6.5	4.5	5	0.5	25	6.5	6.5	4.5	5	0.5	25	7.5	10	6.0	5	0.5	50												
0.22	224	6.5	6.5	4.5	5	0.5	25	6.5	6.5	4.5	5	0.5	25	7.5	10	6.0	5	0.5	50												
0.27	274	6.5	6.5	4.5	5	0.5	25	6.5	6.5	4.5	5	0.5	25	7.5	11	7.0	5	0.5	50												
0.33	334	6.5	6.5	4.5	5	0.5	25	6.5	6.5	4.5	5	0.5	25	7.5	11	7.0	5	0.5	50												
0.39	394	6.5	6.5	4.5	5	0.5	25	6.5	6.5	4.5	5	0.5	25	7.5	12	8.0	5	0.5	50												
0.47	474	7.0	7.5	4.5	5	0.6	25	7.0	7.5	4.5	5	0.6	25	7.5	12	8.5	5	0.5	50												
0.56	564	7.0	8.5	5.0	5	0.6	25	7.0	8.5	5.0	5	0.6	25																		
0.68	684	7.0	8.5	5.0	5	0.6	25	7.0	8.5	5.0	5	0.6	25																		
0.82	824	7.0	8.5	5.0	5	0.6	25	7.0	10	6.0	5	0.6	25																		
1.0	105	7.0	10	6.5	5	0.5	25	7.0	10	6.0	5	0.6	25																		
1.2	125	7.0	10	6.5	5	0.6	20	7.0	11	7.0	5	0.6	20																		

PERFORMANCE

Item	Metalized Polyester
Capacitance Drift	Cycled through the operating temperature range 2%.
Humidity Test	Will withstand the test of R.H. 95% at 40°C for 1000hrs. C ≤ 5% DF < 1.2% IR > 10000MΩ
Load Test	Will withstand a testing voltage at 140% of W.V. for 1000hrs at 85°C. C ≤ 5% DF < 1.2% IR > 5000MΩ
Lead Pull Test	Will withstand a pull of 1.5Kg applied axially for 10 seconds.
Lead Bend Test	Will sustain two cycles without breaking when attaching a load of 0.5Kg to the end of the lead and then rotating the capacitor 90° from the direction of lead egress. Then 180 in opposite direction, then back to the starting point.
Solderability	Immersed in molten solder (230 ± 0.5 sec.) after testing, the wound lead and gap in the wound lead will be covered and filled by solder. Will be difficult to unwind by finger.
Dielectric Strength	Shall withstand 200% or 160% of rated voltage at 25°C for 1 minute with current limiting resistance of 1 Ω / V.

■ **SOLDERING**

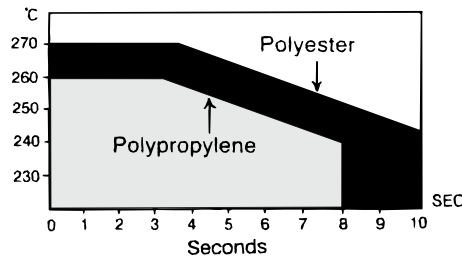

The area under the curve is the recommended soldering time & temp. for the materials shown.

■ **RADIAL TAPING**

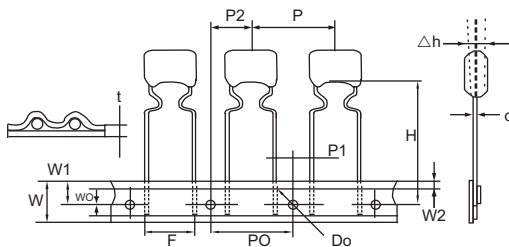

Fig. 1
F=5mm
(RT1)

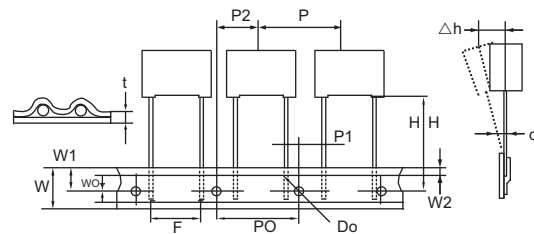

Fig. 2
F=5mm
(RT1)

■ **SPECIFICATIONS**

Description	Letter	Dimension (mm)
		RT1
Lead Wire Diameter	d	0.5 / 0.6
Tapping Pitch	P	12.7
Feed Hole Pitch	PO	12.7
Centering of the Lead Wire	P1	3.85
Centering of the Body	P2	6.35
Lead Spacing (Pitch)	F	5
Component Alignment	Δh	0
Height of Component from Tape Center	H	18.5
Carrier Tape Width	W	18
Hold Down Tape Width	WO	6
Hole Position	W1	9
Hold Down Tape Position	W2	3
Feed Hole Diameter	Do	4
Tape Thickness	t	0.7
Figure	fig	1 or 2

Remark: *Allowance of accumulated pitch less than 1mm at the sum of 20 pitches.
*Continuous empty component less than 3 consecutive pieces.
*Total empty on one reel less than 1%.