

### INTRODUCTION

MDF Series are constructed with metalized polyester film dielectric, copperplated lead and epoxy resin coating. They are suitable for blocking, coupling, decoupling, filtering, bypass timing circuit and ideal for use in data / telecomm equipment, industrial instrument, automatic control systems and other general electronic application.

### PART NUMBER EXAMPLE

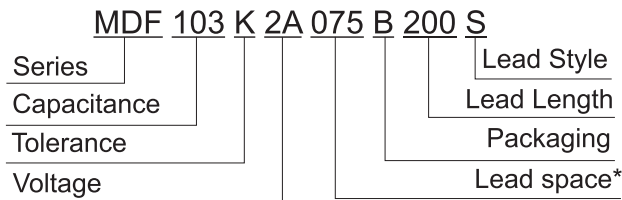

\* Lead space is straight lead non-formed original lead space.

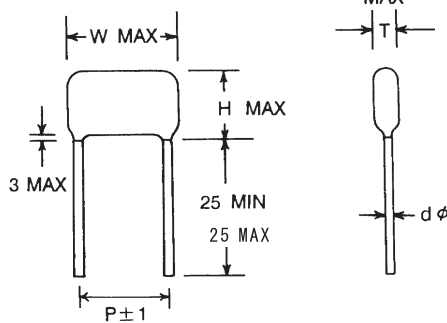

### FEATURES

- High moisture resistance
- Good solderability
- Non-inductive construction
- Self-healing property

### SPECIFICATIONS LEAD STYLE EXAMPLES

Item	Performance
Operating Temp. Range	-40°C ~125°C (VR Derates 1.25% per °C over 105°C)
Capacitance Range	0.01μF ~ 10μF
Capacitance Tolerance	± 5%(J), 10%(K), +20%(M)
Rated Voltage VR 85°C	100Vdc, 250Vdc, 400Vdc, 630Vdc
Dissipation Factor	1.0%(0.01)max @ 1Khz, 25°C
Insulation Resistance	VR ≤ 100Vdc ≥ 15000MΩ (C ≤ 0.33μF) ≥ 5000MΩ x μF (C > 0.33μF) VR ≤ 100Vdc ≥ 30000MΩ (C ≤ 0.33μF) ≥ 10000MΩ x μF (C > 0.33μF)

### TOLERANCE

Code	Tolerance
J	± 5%
K	± 10%
M	± 20%

### LEAD STYLE EXAMPLES

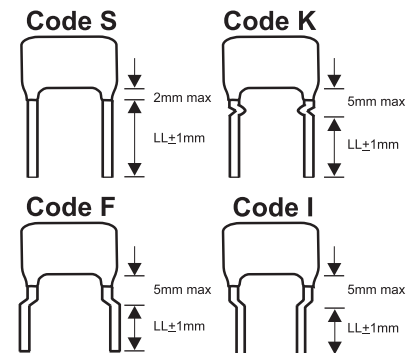

Typical length (LL) is 20 mm for straight lead, bulk pack

### CAPACITANCE CODE

μF	0.01	0.047	0.1	0.47	1.0	4.7	10
pF	10000	47000	100000	470000	-	-	-
Code	103	473	104	474	105	475	106

### RATED VOLTAGE RADIAL LEAD SPACING

WV	100	250	400	630
Code	2A	2E	2G	2J

### PACKAGING

Method	Bulk	Ammo	Reel
Code	B	A	R

### RADIAL LEAD SPACING

\* Lead space is straight lead non-formed original lead space.

mm	7.5	10	15	20	27.5	32.5	37.5	42.5
Code	075	100	150	200	275	325	375	425

### LEAD LENGTH FROM SEATING THE PLANE

mm	5	10	15	20	25
Code	050	100	150	200	250

### TAPE CODE (Lead spacing of tape, if taped)

Spacing	7.5mm	10mm	15mm
Packing	A or R	A	A
Code	RT2	RT3	RT4

### LEAD STYLE

Code	Style
S	Straight
K	Kink-In (Stand Off)
F	Form Out
I	Form In

### ■ MAXIMUM DIMENSIONS (mm)

(μF)	W.V.	50VDC(1H) and 100VDC(2A)					250VDC (2E)					400VDC (2G)					630VDC (2J)				
		Code	W	H	T	P	dφ	W	H	T	P	dφ	W	H	T	P	dφ	W	H	T	P
0.01	103	10.5	9.0	5.5	7.5	0.6	10.5	9.0	5.5	7.5	0.6	10.5	9.0	5.5	7.5	0.6	13.0	10.0	6.0	10.0	0.6
0.015	153	10.5	9.5	6.0	7.5	0.6	10.5	9.5	6.0	7.5	0.6	10.5	9.5	6.0	7.5	0.6	13.0	10.5	6.5	10.0	0.6
0.022	223	10.5	9.5	6.0	7.5	0.6	10.5	9.5	6.0	7.5	0.6	13.0	9.5	6.0	10.0	0.6	13.0	12.5	7.5	10.0	0.6
0.033	333	10.5	9.5	6.0	7.5	0.6	10.5	9.5	6.0	7.5	0.6	13.0	10.0	6.5	10.0	0.6	18.5	12.0	6.5	15.0	0.6
0.047	473	10.5	9.5	6.0	7.5	0.6	10.5	9.5	6.0	7.5	0.6	13.0	12.0	7.0	10.0	0.6	18.5	12.5	7.5	15.0	0.6
0.068	683	10.5	9.5	6.0	7.5	0.6	10.5	10.0	6.5	7.5	0.6	13.0	13.0	8.0	10.0	0.6	18.5	14.0	8.5	15.0	0.8
0.1	104	10.5	9.5	6.0	7.5	0.6	13.0	10.0	6.5	10.0	0.6	18.0	12.5	7.0	15.0	0.8	18.5	14.5	10.0	15.0	0.8
0.15	154	13.0	9.0	5.5	10.0	0.6	18.5	11.0	6.0	15.0	0.6	18.5	13.5	8.0	15.0	0.8	23.0	15.0	9.5	20.0	0.8
0.22	224	13.0	10.0	6.5	10.0	0.6	18.5	11.5	6.5	15.0	0.6	22.5	14.5	8.0	20.0	0.8	23.0	15.5	10.0	20.0	0.8
0.33	334	13.0	11.5	8.0	10.0	0.6	18.5	12.0	7.0	15.0	0.8	22.5	15.0	9.0	20.0	0.8	32.0	19.0	12.0	27.5	0.8
0.47	474	18.5	11.0	6.0	15.0	0.6	22.5	12.5	7.5	20.0	0.8	22.5	18.5	11.5	20.0	0.8	32.0	22.0	13.5	27.5	0.8
0.68	684	18.5	12.5	7.5	15.0	0.6	22.5	13.5	8.5	20.0	0.8	32.0	19.0	12.0	27.5	0.8	36.0	22.5	14.5	32.5	0.8
1	105	18.5	13.5	8.5	15.0	0.8	22.5	15.0	10.0	20.0	0.8	32.0	21.5	13.5	27.5	0.8	36.0	29.0	16.0	32.5	0.8
1.5	155	22.5	14.5	8.0	20.0	0.8	32.0	17.5	9.5	27.5	0.8	36.0	23.5	14.0	32.5	0.8	42.0	29.5	18.5	37.5	1.0
2.2	225	22.5	16.5	10.0	20.0	0.8	32.0	19.0	10.5	27.5	0.8	36.0	27.5	18.5	32.5	0.8	46.0	32.5	20.5	42.5	1.0
3.3	335	22.5	20.0	12.0	20.0	0.8	32.0	23.0	13.5	27.5	0.8	42.0	30.5	18.5	37.5	1.0					
4.7	475	22.5	21.5	14.0	20.0	0.8	36.0	24.0	14.0	32.5	0.8	46.0	34.0	22.0	42.5	1.0					
6.8	685	32.0	23.5	14.5	27.5	0.8	42.0	27.0	16.0	37.5	1.0										
10	106	32.0	29.0	18.0	27.5	0.8	42.0	35.0	19.0	37.5	1.0										

### ■ PERFORMANCE

Item	Metalized Polyester
Capacitance Drift	Cycled through the operating temperature range 2%
Humidity Test	Will withstand the test of R.H. 95% at 40°C for 1000hrs. C ≤ 5% DF < 1.2% IR > 10000MΩ
Load Test	Will withstand a testing voltage at 140% of W.V. for 1000hrs at 85 °C. C ≤ 5% DF < 1.2% IR > 5000MΩ
Lead Pull Test	Will withstand a pull of 1.5Kg applied axially for 10 seconds
Lead Bend Test	Will sustain two cycles without breaking when attaching a load of 0.5Kg to the end of the lead and then rotating the capacitor 90°C from the direction of lead egress. Then 180°C in opposite direction. Then back to the starting point.
Solderability	Immersed in molten solder 230 ± 0.5sec. After testing, the wound lead and gap in the wound lead will be covered and filled by solder. Will be difficult to unwind by finger.
Dielectric Strength	Shall withstand 200% or 160% of rated voltage at 25°C for 1 minute with current limiting resistance of 1Ω / V

### ■ SOLDERING

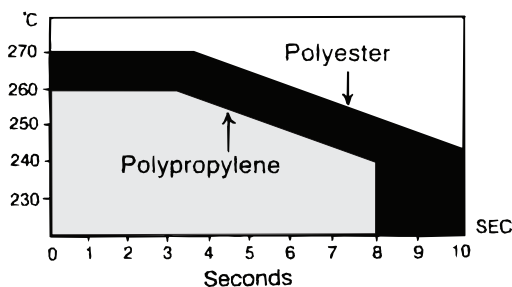

The area under the curve is the recommended soldering time & temp. for the materials shown.