

### INTRODUCTION

The RMTH series are thin film resistors. They feature a lower Temperature Coefficient than standard thick film types and are ideal for use in applications where temperature stability is important. These resistors are lead free.

### FEATURES

- Tolerance to  $\pm 0.1\%$
- Low TCR to  $\pm 10 \text{ ppm}/^\circ\text{C}$
- Halogen free and lead free
- See RMTUH12 for Triple Power

### CONSTRUCTION

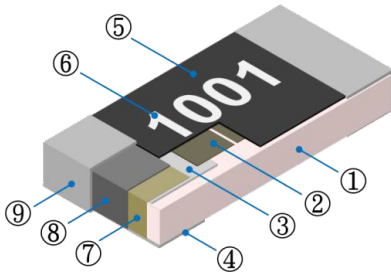

① Alumina Substrate	④ Bottom Inner Electrode	⑦ Side Inner Electrode
② Resistive Layer	⑤ Protective Overcoat	⑧ Nickel Barrier
③ Top Inner Electrode	⑥ Marking	⑨ Solder coating (Sn)

### DIMENSIONS

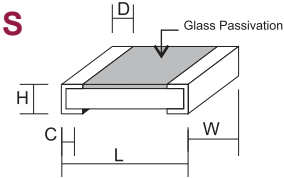

Size Code	Max. Dimension (mm)				
	L	W	H	C	D
RMTH04 (0402)	1.00±0.20	0.50±0.15	0.30±0.05	0.20±0.10	0.20±0.10
RMTH06 (0603)	1.60±0.20	0.80±0.15	0.40±0.10	0.30±0.20	0.30±0.15
RMTH10 (0805)	2.00±0.20	1.25±0.20	0.50±0.15	0.35±0.15	0.35±0.15
RMTH12 (1206)	3.20±0.20	1.60±0.20	0.55±0.15	0.45±0.20	0.45±0.20
RMTH25 (1210)	3.20±0.20	2.50±0.20	0.55±0.15	0.50±0.20	0.50±0.20
RMTH50 (2010)	5.00±0.20	2.50±0.20	0.55±0.10	0.60±0.20	0.60±0.20
RMTH1W (2512)	6.30±0.20	3.20±0.20	0.55±0.10	0.60±0.20	0.60±0.20

### RATINGS & RESISTANCE RANGE

Type	Rated Power at 70°C	Max. Working Voltage	Max. Overload Voltage	T.C.R. (PPM/C)	Resistance Range			
					B(±0.1%)	C(±0.1%)	D(±0.5%)	F(±1%)
RMTH04 (0402)	0.1W	50	100	±10 & ±15	10Ω - 10KΩ			
				±25 & ±50	4.7Ω - 10KΩ	2.49Ω - 10KΩ		
RMTH06 (0603)	0.125W	150	300	±10 & ±15	10Ω - 47KΩ			
				±25 & ±50	4.7Ω - 47KΩ	2.49Ω - 47KΩ		
RMTH10 (0805)	0.25W	200	400	±10 & ±15	10Ω - 100KΩ			
RMTH12 (1206)	0.5W			±25 & ±50	4.7Ω - 100KΩ	2.49Ω - 100KΩ		
RMTH25 (1210)	0.5W			±10 & ±15	10Ω - 100KΩ			
				±25 & ±50	4.7Ω - 100KΩ	2.49Ω - 100KΩ		
RMTH50 (2010)	0.75W			±10 & ±15	10Ω - 100KΩ			
				±25 & ±50	4.7Ω - 100KΩ	2.49Ω - 100KΩ		
RMTH1W (2512)	1W			±10 & ±15	10Ω - 100KΩ			
				±25 & ±50	4.7Ω - 100KΩ	2.49Ω - 100KΩ		

### PART NUMBER EXAMPLE

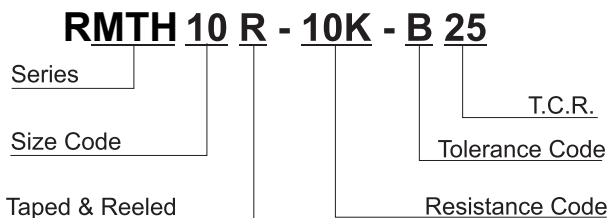

### RESISTANCE CODE

Ohms	2.49	100	1.5K	15K	100K
Code	2R49	100R	1K5	15K	100K

### TOLERANCE CODE

Tolerance	± 0.1%	± 0.25%	± 0.5%	± 1%
Code	B	C	D	F

■ **PERFORMANCE CHARACTERISTICS**

■ **POWER DERATING CURVE**

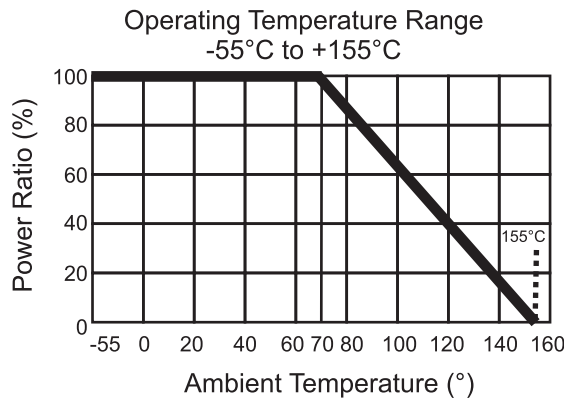

Power rating or current rating is in the case based on continuous full-load at ambient temperature of 70°C. For operation at ambient temperature in excess of 70°C, the load should be derated in accordance with figure of derating Curve.

■ **VOLTAGE RATING OR CURRENT RATING**

Resistance Range: ≥1Ω

Rated Voltage: The resistor shall have a DC continuous working voltage or a RMS AC continuous working voltage at commercial-line frequency and wave form corresponding to the power rating, as determined formula as follows:

$$E = \sqrt{P \times R}$$

E = Rated Voltage (V)

P = Power Rating (W)

R = Nominal Resistance (Ω)

■ **OPERATION AND STORAGE TEMPERATURE**

TYPE	MIN	MAX
Operation temperature	-55°C	70°C
Storage temperature	20°C	30°C
Storage humidity	30%	70°C

■ **SOLDERING PROFILE**

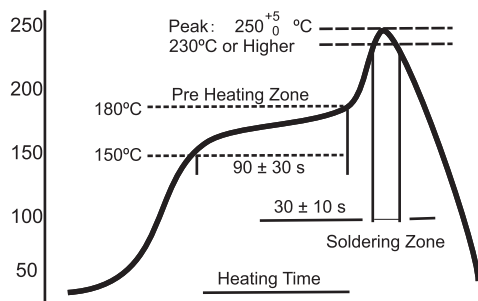

■ **TEST PROCEDURES & REQUIREMENTS**

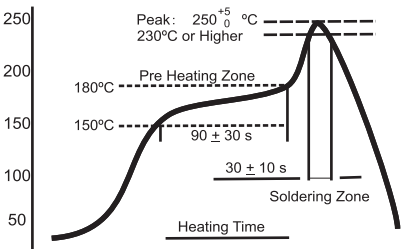
Test Item	Test Method	Procedure	Requirements
Temperature Coefficient of Resistance (T.C.R.)	JIS C 5201-1 Clause 4.8	-55°C ~ +155°C, 20°C is the reference temperature	Refer to Ratings
Short Time Overload	JIS C 5201-1 Clause 4.13	General: 2.5 times RCWV or Max. Overload voltage for 5 seconds High Power: 2.5 times RCWV or Max. Overload voltage for 2 seconds	±1: ±(1.0%+0.05Ω) ±5: ±(2.0%+0.1Ω)
IR Reflow	Sony SS-00254		±1: ±(1.0%+0.05Ω) ±5: ±(2.0%+0.1Ω)
Leaching	Sony SS-00254-9	260 ±5°C for 30 seconds	> 95% Coverage
Soldering Heat	JIS C 5201-1 Clause 4.18	260 ±5°C for 10 seconds	±1: ±(0.5%+0.05Ω) ±5: ±(1.0%+0.05Ω)
Temperature Cycling	JIS C 5201-1 Clause 4.19	-55°C ~ +155°C, 5 cycles	0.1% ' 0.5% ' 1% ±(0.5%+0.05Ω) 2% ' 5% ±(1.0%+0.1Ω)
Electric Iron	Sony SS-00254-5	Preheating temperature: 350 ± 5°C Electric Iron preheating time: 3 +1/-0 sec.	±1: ±(0.5%+0.05Ω) ±5: ±(1.0%+0.05Ω)
Resistance to Solvent	JIS C 5201-1 Clause 4.29	The tested resistor be immersed into isopropyl alcohol of 20~25°C for 60 seconds. Then the resistor is left in the room for 48 hours.	±1: ±(0.5%+0.05Ω) ±5: ±(1.0%+0.05Ω)
Load Life in Humidity	JIS C 5201-1 Clause 4.24	40 ± 2°C, 90~95% R.H. or Max. working voltage for 1000 hours with 1.5 hrs "ON" and 0.5hr "OFF".	0.1% ' 0.5% ' 1% ±(0.5%+0.05Ω) 2% ' 5% ±(3.0%+0.1Ω)
Load Life (Endurance)	JIS C 5201-1 Clause 4.25	70 ± 2°C, or Max. working voltage for 1000 hours with 1.5 hrs "ON" and 0.5hr "OFF".	0.1% ' 0.5% ' 1% ±(1.0%+0.05Ω) 2% ' 5% ±(3.0%+0.1Ω)
Terminal Bending Strength	JIS C 5201-1 Clause 4.33	<b>Bend once for 5 seconds</b> <b>RM Series 0402, 0603, 0805 = 5mm</b> <b>RM Series 1206, 1210, 1812 = 3mm</b> <b>RM Series 1218, 2010, 2512 = 2mm</b>	±1: ±(1.0%+0.05Ω) ±5: ±(1.0%+0.05Ω)
Insulation Resistance	JIS C 5201-1 Clause 4.6	Max Overload Voltage for 1 min.	≥ 10G

■ **PACKAGE & DIMENSION**

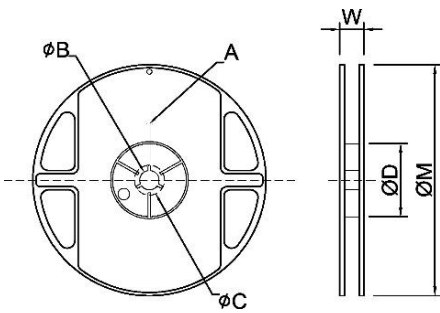

Unit:mm

Size	Package Q'ty	A	$\phi B$	$\phi C$	$\phi D$	W	$\phi M$
RMTH02(0201) RMTH04(0402)	7" 10K/reel	2.0±0.5	13.5±1.0	21±1.0	60±1.0	11.5±2.0	178±2.0
RMTH06(0603)	7" 5K/reel	2.0±0.5	13.5±1.0	21±1.0	60±1.0	11.5±2.0	178±2.0
RMTH10(0805)	10" 10K/reel	2.0±0.5	13.5±1.0	21±1.0	100±1.0	11.5±2.0	254±2.0
RMTH12(1206)	13" 20K/reel	2.0±0.5	13.5±1.0	21±1.0	100±1.0	11.5±2.0	330±2.0
RMTH25(1210)	7" 5K/reel	2.0±0.5	13.5±1.0	21±1.0	60±1.0	11.5±2.0	178±2.0
RMTH50(2010)	7" 4K/reel	2.0±0.5	13.5±1.0	21±1.0	60±1.0	16.0±2.0	178±2.0
RMTH75(2512)							

■ **TAPING SPECIFICATION**

Paper Type  
(P= 2.0 ± 0.1)

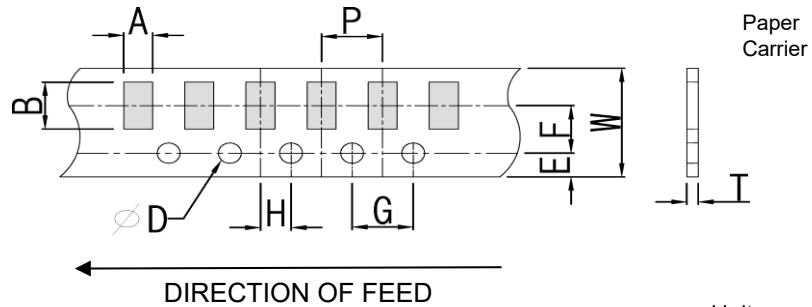

Unit:mm

Size	A	B	W	E	F	G	H	T	$\phi D$
RMTH02(0201)	0.45±0.10	0.75±0.10	8.0±0.20	1.75±0.10	3.5±0.05	4.0±0.10	2.0±0.05	0.35±0.10	1.50±0.10
RMTH04(0402)	0.70±0.10	1.20±0.10	8.0±0.20	1.75±0.10	3.5±0.05	4.0±0.10	2.0±0.05	0.45±0.10	1.50±0.10
RMTH06(0603)	1.05±0.20	1.80±0.20	8.0±0.20	1.75±0.10	3.5±0.05	4.0±0.10	2.0±0.05	0.60±0.10	1.50±0.10
RMTH10(0805)	1.55±0.20	2.30±0.20	8.0±0.20	1.75±0.10	3.5±0.05	4.0±0.10	2.0±0.05	0.75±0.10	1.50±0.10
RMTH12(1206)	1.90±0.20	3.50±0.20	8.0±0.20	1.75±0.10	3.5±0.05	4.0±0.10	2.0±0.05	0.75±0.10	1.50±0.10
RMTH25(1210)	2.85±0.20	3.50±0.20	8.0±0.20	1.75±0.10	3.5±0.05	4.0±0.10	2.0±0.05	0.75±0.10	1.50±0.10

Embossed Type  
(P= 4.0 ± 0.1)  
(2W.P= 8.0 ± 0.2)

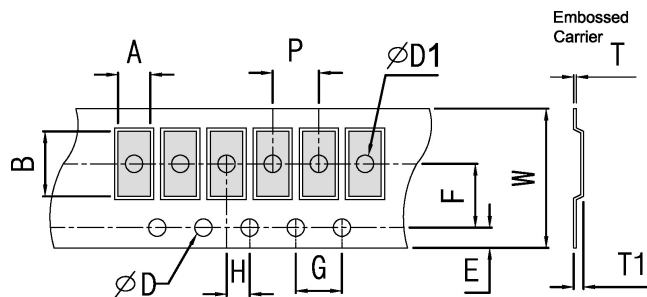

Unit:mm

Size	A	B	W	E	F	G	H	T	$\phi D$	$\phi D1$	T1
RMTH50(2010)	2.80±0.20	5.60±0.20	12±0.10	1.75±0.10	5.5±0.05	4.0±0.10	2.0±0.05	0.23±0.10	1.50±0.10	1.50±0.10	0.85±0.15
RMTH75(2512)	3.30±0.20	4.60±0.20	12±0.10	1.75±0.10	5.5±0.05	4.0±0.10	2.0±0.05	0.23±0.10	1.50±0.10	1.50±0.10	0.85±0.15