

**FEATURES**

- 105°C, 2000 ~ 5000 hours assured.
- Low ESR, suitable for switching power supplies.
- Smaller size with large permissible ripple current.

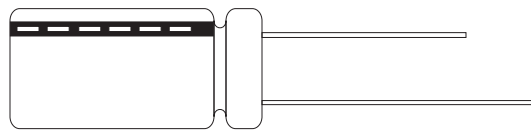

**SPECIFICATIONS**

Item	Performance								
Operating Temperature	6.3 ~ 63V	100V							
	-55°C ~ +105°C	-40°C ~ +105°C							
Capacitance Tolerance	± 20% (120Hz, 20°C)								
Leakage Current (at 20°C)	I = 0.01CV or 3 (μA) whichever is greater (after 2 minutes) Where, C = rated capacitance in μF, V = rated DC working voltage in V								
Dissipation Factor Tan δ at 120 Hz, 20°C	Rated Voltage	6.3    10    16    25    35    50    63    100							
	Tan d (max)	0.22    0.19    0.16    0.14    0.12    0.10    0.08    0.05							
When the capacitance exceed 1000 μF 0.02 shall be added every 1000 μF.									
Low Temperature Characteristics (at 120Hz)	Impedance ratio shall not exceed the values given in the table below								
	Rated Voltage	6.3	10	16	25	35	50	63	100
Impedance Ratio	Z(-55°C)/Z(+20°C)	4	4	3	3	3	3	3	3
Load Life Test	Test Time	2000hrs for ϕD = 5~8mm 5000hrs for ϕD > 10mm							
	Capacitance Change	Within ± 20% of initial value							
	Dissipation Factor	Less than 200% of specified value.							
	Leakage Current	Within specified value							
* The above specifications shall be satisfied when the capacitors are restored to 20°C after the rated voltage applied with rated ripple current for 2,000/5,000 hours at 105°C.									
Shelf Life Test	Test Time	1000 Hrs							
	Capacitance Change	Within ± 20%							
	Dissipation Factor	Less than 200% of specified value							
	Leakage Current	Within Specified value							
* The above specifications shall be satisfied when the capacitors are restored to 20°C after exposing them for 1,000 hours at 105°C without voltage applied.									
Ripple Current & Frequency Multipliers	Freq. (Hz)	60(50)	120	500	1K	10K	100K		
	Cap. (μF)	60(50)	120	500	1K	10K	100K		
	Under 33	0.40	0.55	0.65	0.80	0.90	1.00		
	39 to 330	0.60	0.70	0.80	0.90	0.95	1.00		
	390 to 1000	0.65	0.80	0.85	0.98	1.00	1.00		
1200 up above	0.80	0.90	0.95	0.98	1.00	1.00			

**LEAD SPACING AND DIAMETER**

ϕD	5	6.3	8	10	13	16	18
P	2.0	2.5	3.5	5.0	5.0	7.5	7.5
ϕd	0.5		0.6		0.8		
α	1.0			1.5			
β	0.5						

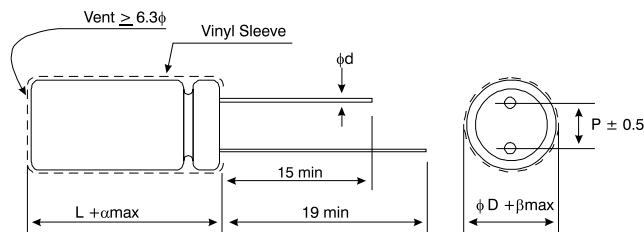

### ■ DIMENSIONS AND PERMISSIBLE RIPPLE CURRENT

Dimension:  $\phi D \times L$ (mm)

Ripple Current: mA/rms at 100K Hz 105°C

VDC Item $\mu F$	6.3V(0J)					10V(1A)					16V(1C)				
	$\phi D \times L$	Impedance ( $\Omega$ ) Max @ 100KHz		Ripple current (mA rms) @ 105°C		$\phi D \times L$	Impedance ( $\Omega$ ) Max @ 100KHz		Ripple current (mA rms) @ 105°C		$\phi D \times L$	Impedance ( $\Omega$ ) Max @ 100KHz		Ripple current (mA rms) @ 105°C	
		20°C	-10°C	120Hz	100KHz		20°C	-10°C	120Hz	100KHz		20°C	-10°C	120Hz	100KHz
		33													5 x 11
39											5 x 11	1.30	3.90	108	154
47						5 x 11	2.10	5.50	78	111	6.3 x 11	0.60	1.80	182	260
56						5 x 11	1.90	4.80	85	121	6.3 x 11	0.60	1.80	182	260
68						5 x 11	1.30	3.90	108	154	6.3 x 11	0.60	1.80	182	260
100	5 x 11	1.30	3.90	108	154	6.3 x 11	0.60	1.80	182	260	6.3 x 11	0.60	1.80	182	260
220	6.3 x 11	0.60	1.80	182	260	8 x 11.5	0.33	0.99	280	400	8 x 11.5	0.33	0.99	320	400
330	8 x 11.5	0.33	0.88	280	400	8 x 11.5	0.33	0.99	280	400	10 x 12.5	0.25	0.75	360	510
390	8 x 11.5	0.33	0.88	320	400	10 x 12.5	0.27	0.70	410	510	10 x 16	0.19	0.57	510	635
470	10 x 12.5	0.25	0.75	410	510	10 x 12.5	0.25	0.75	410	510	10 x 16	0.19	0.57	510	635
560	10 x 12.5	0.25	0.75	410	510	10 x 16	0.19	0.57	510	635	10 x 20	0.14	0.42	775	860
680	10 x 16	0.19	0.57	510	635	10 x 16	0.19	0.57	510	635	10 x 20	0.14	0.42	775	860
1000	10 x 20	0.14	0.42	690	860	10 x 20	0.14	0.37	690	860	12.5 x 20	0.085	0.26	1000	1250
1200	10 x 20	0.14	0.42	775	860	10 x 25	0.12	0.30	930	1030	12.5 x 20	0.085	0.26	1125	1250
2200	12.5 x 20	0.085	0.26	1125	1250	12.5 x 25	0.070	0.21	1200	1355	12.5 x 25	0.070	0.21	1200	1355
3300	12.5 x 25	0.070	0.21	1200	1355	12.5 x 25	0.070	0.21	1200	1355	16 x 31.5	0.048	0.14	1830	2030
4700	16 x 25	0.060	0.18	1595	1770	16 x 31.5	0.048	0.14	1830	2030	16 x 35.5	0.044	0.13	2065	2295

VDC Item $\mu F$	25V(1E)					35V(1V)					50V(1H)				
	$\phi D \times L$	Impedance ( $\Omega$ ) Max @ 100KHz		Ripple current (mA rms) @ 105°C		$\phi D \times L$	Impedance ( $\Omega$ ) Max @ 100KHz		Ripple current (mA rms) @ 105°C		$\phi D \times L$	Impedance ( $\Omega$ ) Max @ 100KHz		Ripple current (mA rms) @ 105°C	
		20°C	-10°C	120Hz	100KHz		20°C	-10°C	120Hz	100KHz		20°C	-10°C	120Hz	100KHz
		1													5 x 11
2.2											5 x 11	4.0	12.0	48	88
3.3											5 x 11	3.50	11.0	52	94
4.7											5 x 11	3.00	9.00	55	100
6.8											5 x 11	3.00	9.00	55	100
10											5 x 11	2.00	6.00	68	124
22						5 x 11	1.30	3.90	108	154	6.3 x 11	0.60	1.80	143	260
33	5 x 11	1.30	3.90	108	154	6.3 x 11	0.60	1.80	182	260	6.3 x 11	0.60	1.80	143	260
39	6.3 x 11	0.60	1.80	182	260	6.3 x 11	0.60	1.80	182	260	6.3 x 11	0.60	1.80	182	260
47	6.3 x 11	0.60	1.80	182	260	6.3 x 11	0.60	1.80	182	260	8 x 11.5	0.33	0.99	320	400
56	6.3 x 11	0.60	1.80	182	260	6.3 x 11	0.60	1.80	182	260	8 x 11.5	0.33	0.99	320	400
68	6.3 x 11	0.60	1.80	182	260	6.3 x 11	0.60	1.80	182	260	8 x 11.5	0.33	0.99	320	400
100	8 x 11.5	0.33	0.99	320	400	8 x 11.5	0.33	0.99	320	400	10 x 16	0.19	0.57	445	635
220	10 x 12.5	0.25	0.75	360	510	10 x 16	0.19	0.57	445	635	10 x 25	0.12	0.30	825	1030
330	10 x 16	0.19	0.57	445	635	10 x 20	0.12	0.42	600	860	12.5 x 20	0.085	0.26	875	1250
390	10 x 20	0.14	0.42	775	635	10 x 25	0.12	0.30	930	1030	12.5 x 25	0.070	0.21	1085	1355
470	10 x 20	0.14	0.42	775	635	12.5 x 20	0.085	0.26	1000	1250	12.5 x 25	0.070	0.21	1085	1355
560	10 x 25	0.12	0.30	930	1030	12.5 x 20	0.085	0.26	1000	1250	12.5 x 25	0.070	0.21	1085	1355
680	12.5 x 20	0.085	0.26	1000	1250	12.5 x 25	0.070	0.21	1085	1355	16 x 25	0.060	0.18	1415	1770
1000	12.5 x 25	0.070	0.23	1080	1355	12.5 x 25	0.070	0.21	1085	1355	16 x 25	0.060	0.18	1595	1770
1200	12.5 x 25	0.070	0.21	1200	1355	12.5 x 25	0.070	0.21	1200	1355	16 x 31.5	0.048	0.14	1830	2030
2200	16 x 25	0.060	0.18	1595	1770	16 x 35.5	0.044	0.13	2065	2295	18 x 40	0.037	0.1	2465	2740
3300	16 x 35.5	0.044	0.13	2065	2295	18 x 40	0.037	0.10	2465	2740					
4700	18 x 40	0.037	0.1	2465	2740										

### DIMENSIONS AND PERMISSIBLE RIPPLE CURRENT

Dimension:  $\phi D \times L$ (mm)

Ripple Current: mA/rms at 100K Hz 105°C

VDC Item $\mu F$	63V(1J)					100V(2A)				
	$\phi D \times L$	Impedance		Ripple current		$\phi D \times L$	Impedance		Ripple current	
		( $\Omega$ ) Max @ 100KHz		(mA rms) @ 105°C			( $\Omega$ ) Max @ 100KHz		(mA rms) @ 105°C	
		20°C	-10°C	120Hz	100KHz		20°C	-10°C	120Hz	100KHz
1						5 x 11	7.00	25	36	66
2.2						5 x 11	6.00	21	40	72
3.3						5 x 11	5.00	18.0	43	78
4.7						6.3 x 11	1.20	4.20	100	180
6.8						6.3 x 11	1.20	4.20	100	180
10	6.3 x 11	1.20	4.2	100	180	8 x 11.5	0.56	2.00	168	305
22	6.3 x 11	1.20	4.2	100	180	8 x 11.5	0.56	2.00	168	308
33	8 x 11.5	0.56	2.00	170	305	10 x 12.5	0.50	1.80	210	380
39	8 x 11.5	0.56	2.00	170	305	10 x 16	0.32	1.10	350	500
47	8 x 11.5	0.56	2.00	170	305	10 x 20	0.27	0.95	435	620
56	10 x 12.5	0.50	1.80	265	380	10 x 20	0.27	0.95	435	620
68	10 x 12.5	0.50	1.80	265	380	10 x 25	0.21	0.63	530	760
100	10 x 20	0.27	0.95	600	620	13 x 20	0.16	0.56	625	890
220	12.5 x 20	0.094	0.24	570	820	16 x 25	0.090	0.32	1010	1440
330	12.5 x 25	0.073	0.21	770	1100	16 x 31.5	0.060	0.17	1255	1790
390	12.5 x 25	0.073	0.21	770	1100	16 x 35.5	0.056	0.14	1650	2065
470	16 x 25	0.060	0.18	1420	1770					
560	16 x 31.5	0.048	0.14	1625	2030					
680	16 x 31.5	0.048	0.14	1625	2030					
1000	18 x 35.5	0.041	0.11	1790	2240					

### PART NUMBER EXAMPLE

RXJ    101    M    1E    BK    080115  
 Series Name    Capacitance    Tolerance    Rated Voltage    Package    Case Size

1. Series: RXJ

2. Capacitance: Rated capacitance in  $\mu F$  is represented by a three digit number. The first two digits are the significant figures of the nominal capacitance and the third digit indicates the number of zeros following these figures. The decimal point is represented by the capital letter R. Please refer to the following example.

$\mu F$	0.1	0.47	1	4.7	10	47	100	470	1000	4700	10000
Code	0R1	R47	010	4R7	100	470	101	471	102	472	103

■ **PART NUMBER EXAMPLE** (continue)

3. Tolerance: (20% is typically standard, however others are available)

Code	K	M
Tolerance	± 10%	± 20%

4. Rated Voltage: Voltage in volts (V) is represented by a two digit code showing the rated working voltage indicated as follows:

Voltage (V)	6.3	10	16	25	35	50	63	100
Code	0J	1A	1C	1E	1V	1H	1J	2A

5. Lead Forming & Package

Code	Lead Description	Packaging
BC	Bending Cut *	Bulk
BK	Straight Lead	Bulk
CC	Lead Cutting *	Bulk
FC	Lead Forming & Cutting *	Bulk
SC	Snap-in & Cut Lead *	Bulk
SD	Bent Cathode Lead *	Bulk
SF	Snap-in & Formed Cut Lead *	Bulk
SA	Straight Lead Taping	Tape & Ammo
TA	Formed Lead Taping	Tape & Ammo
SR	Straight Lead	Tape & Reel
TR	Lead Forming	Tape & Reel

\* Cutting & Forming Specification: see page 6

6. Can Size: Diameter (mm) x Length (mm)  
080115 represents 6.3mm can diameter, 11mm can length

Note :

- All standard RFE Aluminum Electrolytic Capacitors are Lead (Pb) Free and RoHS compliant.
- PET sleeve is available for those companies that also required PVC free.

■ **TAPING SPECIFICATION FOR RADIAL LEAD TYPE**

Ammo pack box

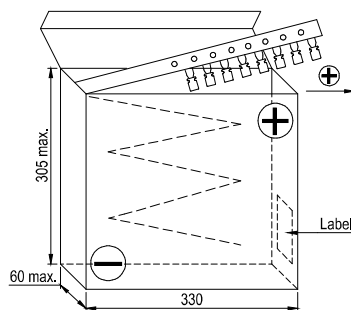

Package Quantity

Unit: pcs / box

φD (mm)	3	4	5	6.3	8	10	12.5
Quantity	3,000	2,500	2,000	2,000	1,000	500	300

Note: The component shall be oriented on the tape as such that the positive lead is leading or the negative lead is leading with customer's request.

**TAPING SPECIFICATION FOR RADIAL LEAD TYPE**

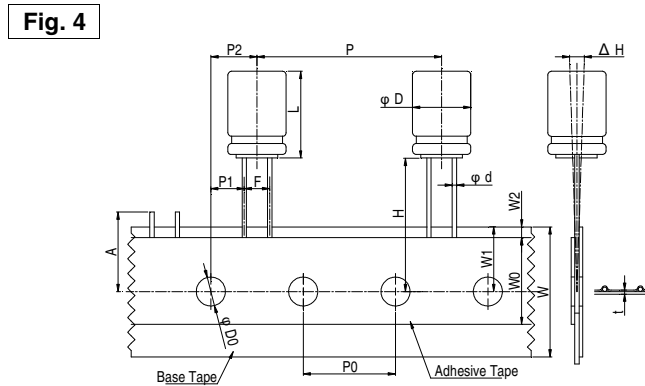
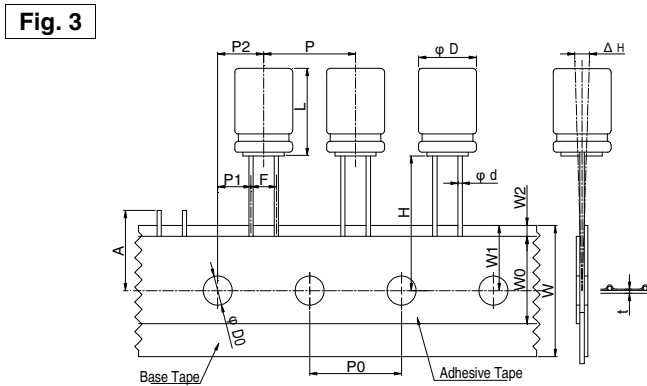
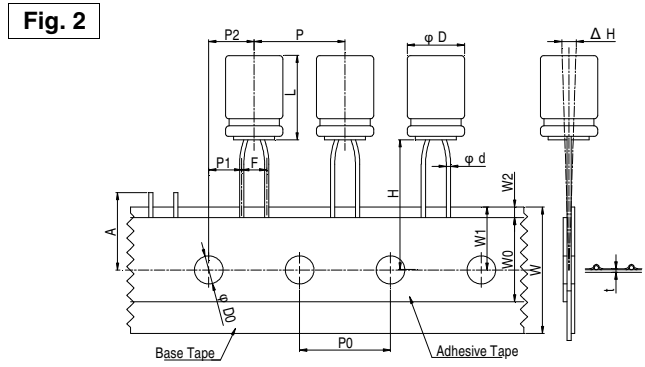
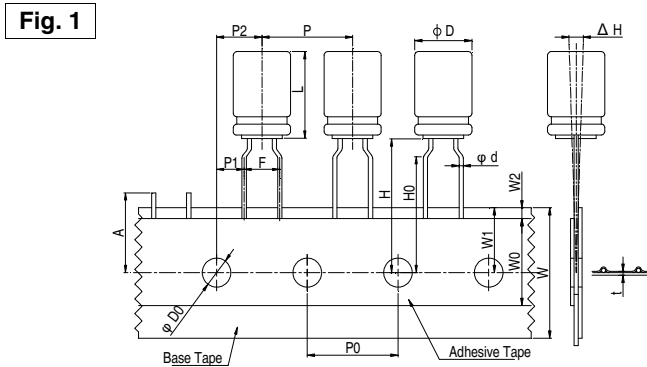

Packing	TA, TR (Fig. 1)								SA, SR (Fig. 2, 3, 4)											
	L ≤ 7mm				L ≥ 7mm				L ≤ 7mm					L ≥ 7mm						
Symbol	φ 3	φ 4	φ 5	φ 6.3	φ 8	φ 5	φ 6.3	φ 8	φ 3	φ 4	φ 5	φ 6.3	φ 8	φ 5	φ 6.3	φ 8	Tol.	φ 10	φ 13	Tol.
φ d	0.4	0.45	0.5	0.5	0.5	0.5	0.5	0.6	0.4	0.45	0.45	0.45	0.45	0.5	0.5	0.6	± 0.05	0.6	0.6	± 0.05
F	5.0	5.0	5.0	5.0	5.0	5.0	5.0	5.0	2.5	2.5	2.5	2.5	3.5	2.5	2.5	3.5	-0.2/+0.8	5.0	5.0	-0.2/+0.8
P	12.7	12.7	12.7	12.7	12.7	12.7	12.7	12.7	12.7	12.7	12.7	12.7	12.7	12.7	12.7	12.7	± 1.0	12.7	25.4	± 1.0
P0	12.7	12.7	12.7	12.7	12.7	12.7	12.7	12.7	12.7	12.7	12.7	12.7	12.7	12.7	12.7	12.7	± 0.2	12.7	12.7	± 0.30
P2	6.35	6.35	6.35	6.35	6.35	6.35	6.35	6.35	6.35	6.35	6.35	6.35	6.35	6.35	6.35	6.35	± 1.0	6.35	6.35	± 1.3
P1	3.85	3.85	3.85	3.85	3.85	3.85	3.85	3.85	5.1	5.1	5.1	5.1	4.6	5.1	5.1	4.6	± 0.5	3.85	3.85	± 0.7
H	17.5	17.5	17.5	17.5	17.5	18.5	18.5	20.0	17.5	17.5	17.5	17.5	17.5	18.5	18.5	18.5	± 0.75	18.5	18.5	± 0.75
H0	16.0	16.0	16.0	16.0	16.0	16.0	16.0	16.0	--	--	--	--	--	--	--	--	± 0.5	--	--	± 0.5
W	18.0	18.0	18.0	18.0	18.0	18.0	18.0	18.0	18.0	18.0	18.0	18.0	18.0	18.0	18.0	18.0	± 0.5	18.0	18.0	± 0.5
W0	12.0	12.0	12.0	12.0	12.0	12.0	12.0	12.0	12.0	12.0	12.0	12.0	12.0	12.0	12.0	12.0	Min	12.0	12.0	Min.
W1	9.0	9.0	9.0	9.0	9.0	9.0	9.0	9.0	9.0	9.0	9.0	9.0	9.0	9.0	9.0	9.0	± 0.5	9.0	9.0	± 0.5
W2	1.5	1.5	1.5	1.5	1.5	1.5	1.5	1.5	1.5	1.5	1.5	1.5	1.5	1.5	1.5	1.5	Max.	1.5	1.5	Max.
φ D0	4.0	4.0	4.0	4.0	4.0	4.0	4.0	4.0	4.0	4.0	4.0	4.0	4.0	4.0	4.0	4.0	± 0.2	4.0	4.0	± 0.2
t	0.7	0.7	0.7	0.7	0.7	0.7	0.7	0.7	0.7	0.7	0.7	0.7	0.7	0.7	0.7	0.7	± 0.2	0.7	0.7	± 0.2
Δ H	0	0	0	0	0	0	0	0	0	0	0	0	0	0	0	0	± 1.0	0	0	± 1.0
ε	1.0	1.0	1.0	1.0	1.0	1.0	1.0	1.0	1.0	1.0	1.0	1.0	1.0	1.0	1.0	1.0	Max.	1.0	1.0	Max.
A	11	11	11	11	11	11	11	11	11	11	11	11	11	11	11	11	Max.	11	11	Max.
Fig. No.	1	1	1	1	1	1	1	1	2	2	2	3	3	2	3	3		3	3,4	

**Lead Forming & Cutting Specification (unit: mm)**

Forming Method	Code	Shape	Dimensions																																															
Forming Cut (4φ~ 8φ)	<b>FC</b>		<table border="1"> <thead> <tr> <th>φD × L</th> <th>φd</th> <th>F</th> <th>F'</th> <th>H</th> </tr> </thead> <tbody> <tr> <td>3 × 5</td> <td>0.4</td> <td>1.0</td> <td rowspan="5">5.0</td> <td rowspan="5">5.0</td> </tr> <tr> <td>4 × 5</td> <td rowspan="3">0.45</td> <td>1.5</td> </tr> <tr> <td>5 × 5</td> <td>2.0</td> </tr> <tr> <td>6.3 ~ 8 × 5</td> <td>2.5</td> </tr> <tr> <td>4 × 7</td> <td rowspan="3">0.5</td> <td>1.5</td> </tr> <tr> <td>5 × 7 ~ 11</td> <td>2.0</td> </tr> <tr> <td>6.3 × 7 ~ 15</td> <td>2.5</td> </tr> <tr> <td>8 × 7 ~ 9</td> <td rowspan="3">0.6</td> <td>3.5</td> <td rowspan="5">---</td> <td rowspan="5">4.5</td> </tr> <tr> <td>8 × 11.5 ~ 50</td> <td>3.5</td> </tr> <tr> <td>10</td> <td>5.0</td> </tr> <tr> <td>12.5</td> <td>5.0</td> </tr> <tr> <td>16</td> <td>0.8</td> <td>7.5</td> </tr> <tr> <td>18</td> <td>0.8</td> <td>7.5</td> </tr> <tr> <td>22</td> <td>1.0</td> <td>10.0</td> </tr> <tr> <td>25</td> <td>1.0</td> <td>12.5</td> </tr> </tbody> </table>	φD × L	φd	F	F'	H	3 × 5	0.4	1.0	5.0	5.0	4 × 5	0.45	1.5	5 × 5	2.0	6.3 ~ 8 × 5	2.5	4 × 7	0.5	1.5	5 × 7 ~ 11	2.0	6.3 × 7 ~ 15	2.5	8 × 7 ~ 9	0.6	3.5	---	4.5	8 × 11.5 ~ 50	3.5	10	5.0	12.5	5.0	16	0.8	7.5	18	0.8	7.5	22	1.0	10.0	25	1.0	12.5
φD × L	φd	F	F'	H																																														
3 × 5	0.4	1.0	5.0	5.0																																														
4 × 5	0.45	1.5																																																
5 × 5		2.0																																																
6.3 ~ 8 × 5		2.5																																																
4 × 7	0.5	1.5																																																
5 × 7 ~ 11		2.0																																																
6.3 × 7 ~ 15		2.5																																																
8 × 7 ~ 9	0.6	3.5	---	4.5																																														
8 × 11.5 ~ 50		3.5																																																
10		5.0																																																
12.5	5.0																																																	
16	0.8	7.5																																																
18	0.8	7.5																																																
22	1.0	10.0																																																
25	1.0	12.5																																																
Cut (3φ~ 25φ)	<b>CC</b>																																																	
Snap-in Forming Cut (4φ~ 8φ)	<b>SF</b>		<table border="1"> <thead> <tr> <th>φD × L</th> <th>φd</th> <th>H1</th> <th>H2</th> <th>H3</th> <th>F</th> <th>P</th> <th>E</th> </tr> </thead> <tbody> <tr> <td>4 ~ 8 × 5</td> <td>0.45</td> <td rowspan="5">5.0</td> <td rowspan="5">2.8</td> <td rowspan="5">2.5</td> <td rowspan="5">5.0</td> <td rowspan="5">1.1</td> <td rowspan="5">1.1</td> </tr> <tr> <td>4 × 7</td> <td>0.45</td> </tr> <tr> <td>5 × 7 ~ 11</td> <td rowspan="3">0.5</td> </tr> <tr> <td>6.3 × 7 ~ 15</td> </tr> <tr> <td>8 × 7 ~ 9</td> </tr> <tr> <td>8 × 11.5 ~ 50</td> <td rowspan="3">0.6</td> <td rowspan="5">4.5</td> <td rowspan="5">2.5</td> <td rowspan="5">---</td> <td rowspan="5">7.5</td> <td rowspan="5">1.2</td> <td rowspan="5">1.3</td> </tr> <tr> <td>10</td> </tr> <tr> <td>12.5</td> </tr> <tr> <td>16</td> <td>0.8</td> </tr> <tr> <td>18</td> <td>0.8</td> </tr> <tr> <td>22</td> <td>1.0</td> <td>10.0</td> </tr> <tr> <td>25</td> <td>1.0</td> <td>12.5</td> </tr> </tbody> </table>	φD × L	φd	H1	H2	H3	F	P	E	4 ~ 8 × 5	0.45	5.0	2.8	2.5	5.0	1.1	1.1	4 × 7	0.45	5 × 7 ~ 11	0.5	6.3 × 7 ~ 15	8 × 7 ~ 9	8 × 11.5 ~ 50	0.6	4.5	2.5	---	7.5	1.2	1.3	10	12.5	16	0.8	18	0.8	22	1.0	10.0	25	1.0	12.5					
φD × L	φd	H1	H2	H3	F	P	E																																											
4 ~ 8 × 5	0.45	5.0	2.8	2.5	5.0	1.1	1.1																																											
4 × 7	0.45																																																	
5 × 7 ~ 11	0.5																																																	
6.3 × 7 ~ 15																																																		
8 × 7 ~ 9																																																		
8 × 11.5 ~ 50	0.6	4.5	2.5	---	7.5	1.2	1.3																																											
10																																																		
12.5																																																		
16	0.8																																																	
18	0.8																																																	
22	1.0	10.0																																																
25	1.0	12.5																																																
Snap-in Cut (10φ~ 25φ)	<b>SC</b>																																																	
Bending Cut (5φ~ 25φ)	<b>BC</b>		<table border="1"> <thead> <tr> <th>φD × L</th> <th>φd</th> <th>F ± 0.5</th> <th>*E max.</th> </tr> </thead> <tbody> <tr> <td>5 × 11</td> <td>0.5</td> <td>2.0</td> <td rowspan="2">---</td> </tr> <tr> <td>6.3 × 11 ~ 15</td> <td>0.5</td> <td>2.5</td> </tr> <tr> <td rowspan="2">8 × 11.5 ~ 50</td> <td rowspan="2">0.6</td> <td>3.5</td> <td rowspan="2">2.3</td> </tr> <tr> <td>5.0</td> </tr> <tr> <td>12.5</td> <td rowspan="3">0.8</td> <td>5.0</td> <td rowspan="3">2.7</td> </tr> <tr> <td>16</td> <td>7.5</td> </tr> <tr> <td>18</td> <td>7.5</td> </tr> <tr> <td>22</td> <td>1.0</td> <td>10.0</td> </tr> <tr> <td>25</td> <td>1.0</td> <td>12.5</td> </tr> </tbody> </table>	φD × L	φd	F ± 0.5	*E max.	5 × 11	0.5	2.0	---	6.3 × 11 ~ 15	0.5	2.5	8 × 11.5 ~ 50	0.6	3.5	2.3	5.0	12.5	0.8	5.0	2.7	16	7.5	18	7.5	22	1.0	10.0	25	1.0	12.5																	
φD × L	φd	F ± 0.5	*E max.																																															
5 × 11	0.5	2.0	---																																															
6.3 × 11 ~ 15	0.5	2.5																																																
8 × 11.5 ~ 50	0.6	3.5	2.3																																															
		5.0																																																
12.5	0.8	5.0	2.7																																															
16		7.5																																																
18		7.5																																																
22	1.0	10.0																																																
25	1.0	12.5																																																
Cathode Lead Bending (10φ~ 25φ)	<b>SD</b>		<p>**E** is only suitable for SD cutting. *BU*: Leads bending cut are different direction from BC.</p>																																															