

■ FEATURES

- 125°C, 3,000 - 5,000 hours assured.
- For high temperature applications

■ SPECIFICATIONS

Items	Performance										
Operating Temperature Range	-40 °C ~ + 125°C										
Capacitance Tolerance	±20% (at 120Hz, 20 °C)										
Leakage Current (at 20 °C)	I = 0.01CV or 3 (μ A) whichever is greater after 2 minutes Where C = rated capacitance in μF. V = rated DC working voltage in V.										
Dissipation Factor (Tan at 120Hz, 20 °C)	Rated Voltage	10	16	25	35	50	63				
	Tan (max)	0.15	0.12	0.10	0.10	0.08	0.08				
Low Temperature Characteristics (at 120Hz)	Impedance ratio shall not exceed the values given in the table below.										
	Rated Voltage		10	16	25	35	50	63			
	Impedance Ratio	Z (-25) / Z (+20 °C)	3	2	2	2	2	2			
Z (-40) / Z (+20 °C)		6	4	4	4	4	4				
Load Life Test	Test Time	3,000 hrs for D ≤ 8 mm 5,000 hrs for D ≥ 10 mm									
	Capacitance Change	Within ± 20% of initial value									
	Dissipation Factor	Less than 200% of specified value									
	Leakage Current	Within specified value									
	* The above specifications shall be satisfied when the capacitors are restored to 20 °C after applied with rated subjected to DC voltage with the rated ripple current is applied for 3,000 / 5,000 hrs at 125 °C										
Shelf Life Test	Test Time	1,000 hours									
	Capacitance Change	Within + 20% of initial value									
	Dissipation Factor	Less than 200% of specified value									
	Leakage Current	Less than 500% of specified value									
	* The above specifications shall be satisfied when the capacitors are restored to 20°C after exposing them for 1,000 hrs at 125 °C without voltage applied. (The procedures before testing JIS C 5102 4.4)										
Other Standards	JIS C 5101-4										

■ DIMENSIONS AND PERMISSIBLE RIPPLE CURRENT

Dimension: D×L(mm)

Ripple Current: mA/RMS at 120Hz 125°C

μ F	VDC Code	10V (1A)		16V (1C)		25V (1E)		35V (1V)		50V (1H)		63V (1J)	
		D x L	mA	D x L	mA	D x L	mA	D x L	mA	D x L	mA	D x L	mA
0.47	R47									8 x 11.5	12	8 x 11.5	12
1	010									8 x 11.5	17	8 x 11.5	17
2.2	2R2									8 x 11.5	26	8 x 11.5	26
3.3	3R3									8 x 11.5	32	8 x 11.5	32
4.7	4R7									8 x 11.5	38	8 x 11.5	38
10	100									8 x 11.5	56	8 x 11.5	56
22	220							8 x 11.5	75	10 x 12.5	99	10 x 12.5	99
33	330					8 x 11.5	92	10 x 12.5	108	10 x 16	133	10 x 16	133
47	470			8 x 11.5	100	10 x 12.5	129	10 x 16	142	10 x 16	159	10 x 20	173
100	101	10 x 12.5	154	10 x 16	190	10 x 16	208	10 x 20	225				
220	221	10 x 16	252	10 x 20	305	12.5 x 20	371	12.5 x 25	403	12.5 x 20	279	12.5 x 20	279
330	331	10 x 16	308	12.5 x 20	414	12.5 x 25	493	16 x 20	503				
470	471	10 x 20	399	12.5 x 25	537	16 x 20	601			16 x 20	459		
1,000	102	16 x 20	715										

■ **LEAD SPACING AND DIAMETER SPECIFICATIONS**

D	8	10	12.5	16
P	3.5	5.0	5.0	7.5
d	0.6		0.8	
α	1.0	1.5		
β	0.5			

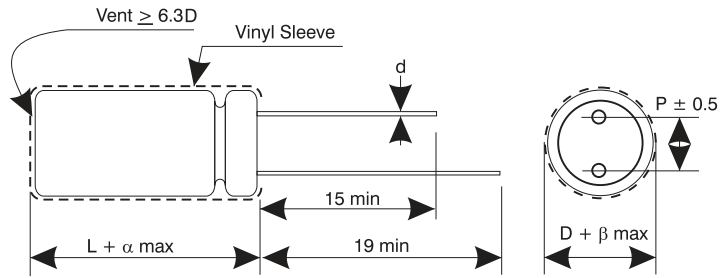

■ **HOW TO MAKE A PART NUMBER**

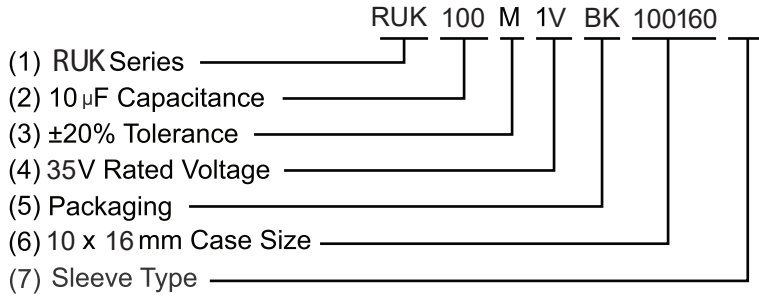

1. Series: RUK

2. Capacitance: Rated capacitance in µF is represented by a three digit number. The first two digits are the significant figures of the nominal capacitance and the third digit indicates the number of zeros following these figures. The decimal point is represented by the capital letter R. Please refer to the following example.

µF	0.1	0.47	1	4.7	10	47	100	470	1000	4700	10000
Part Number	0R1	R47	010	4R7	100	470	101	471	102	472	103

3. Tolerance: (20% IS Typical)

Code	K	M	T	W
Tolerance	± 10%	± 20%	± 50% / -10%	± 100% / -10%

4. Rated Voltage: Voltage in volts (V) is represented by a two digit code showing the rated working voltage indicated as follows:

Voltage (WV)	6.3	10	16	25	35	40	50	63	80	100	160	200	250	350	400	450
Code	0J	1A	1C	1E	1V	1G	1H	1J	1K	2A	2C	2D	2E	2V	2G	2W

5. Lead Forming & Package

Code	Lead Description	Packaging
BC	Bending Cut	Bulk Packing
BK	Straight Lead	Bulk Packing
CC	Lead Cutting	Bulk Packing
FC	Lead Forming & Cutting	Bulk Packing
SD	Cathode Lead Beading	Bulk Packing
SA	Straight Lead	Tape & Ammo
TA	Lead Forming	Tape & Ammo
SR	Straight Lead	Tape & Reel
TR	Lead Forming	Tape & Reel

6. Can Size

Diameter (mm)x10 & Length (mm)x10. Can Size 063110, represents 6.3mm diameter by 11mm length.

7. Sleeve Type* = (Omit) PVC Sleeve

P = PET Sleeve

*Note: All standard RFE Aluminum Electrolytic Capacitors are Lead (Pb) free and RoHS compliant. PET sleeve is available for those companies that also require PVC free product.

LEADED TAPING & PACKAGING SPECIFICATIONS Taping Specification for Radial Lead Type

Fig. 1

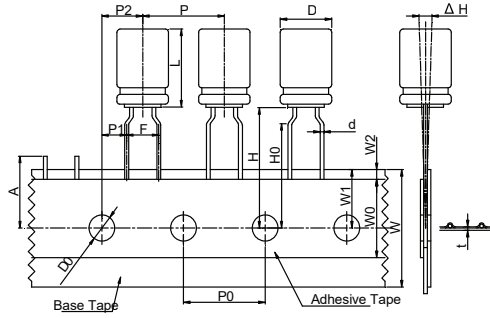

Fig. 2

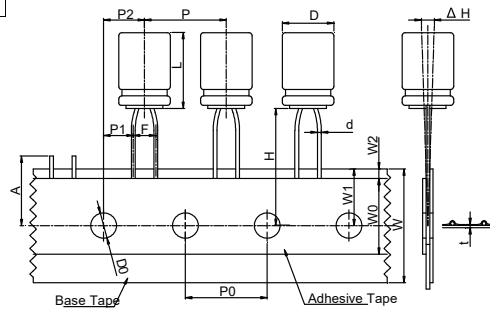

Fig. 3

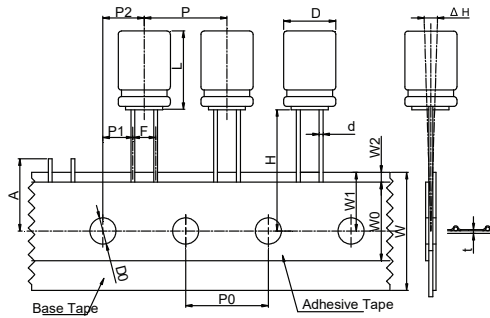
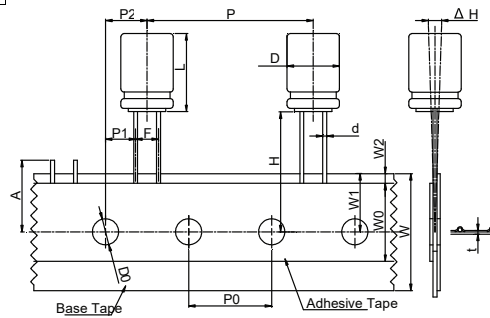

Fig. 4



Packing	TA, TR (Fig. 1)								SA, SR (Fig. 2, 3, 4)											
	L ≤ 7mm				L ≥ 7mm				L ≤ 7mm					L ≥ 7mm						
Symbol	3	4	5	6.3	8	5	6.3	8	3	4	5	6.3	8	5	6.3	8	Tol.	10	13	Tol.
d	0.4	0.45	0.5	0.5	0.5	0.5	0.5	0.6	0.4	0.45	0.45	0.45	0.45	0.5	0.5	0.6	± 0.05	0.6	0.6	± 0.05
F	5.0	5.0	5.0	5.0	5.0	5.0	5.0	5.0	2.5	2.5	2.5	2.5	3.5	2.5	2.5	3.5	-0.2/+0.8	5.0	5.0	-0.2/+0.8
P0	12.7	12.7	12.7	12.7	12.7	12.7	12.7	12.7	12.7	12.7	12.7	12.7	12.7	12.7	12.7	12.7	± 1.0	12.7	25.4	± 1.0
P2	6.35	6.35	6.35	6.35	6.35	6.35	6.35	6.35	6.35	6.35	6.35	6.35	6.35	6.35	6.35	6.35	± 1.0	6.35	6.35	± 1.3
P1	3.85	3.85	3.85	3.85	3.85	3.85	3.85	3.85	5.1	5.1	5.1	5.1	4.6	5.1	5.1	4.6	± 0.5	3.85	3.85	± 0.7
H	17.5	17.5	17.5	17.5	17.5	18.5	18.5	20.0	17.5	17.5	17.5	17.5	17.5	18.5	18.5	18.5	± 0.75	18.5	18.5	± 0.75
H0	16.0	16.0	16.0	16.0	16.0	16.0	16.0	16.0	--	--	--	--	--	--	--	--	± 0.5	--	--	± 0.5
W	18.0	18.0	18.0	18.0	18.0	18.0	18.0	18.0	18.0	18.0	18.0	18.0	18.0	18.0	18.0	18.0	± 0.5	18.0	18.0	± 0.5
W0	12.0	12.0	12.0	12.0	12.0	12.0	12.0	12.0	12.0	12.0	12.0	12.0	12.0	12.0	12.0	12.0	Min	12.0	12.0	Min.
W1	9.0	9.0	9.0	9.0	9.0	9.0	9.0	9.0	9.0	9.0	9.0	9.0	9.0	9.0	9.0	9.0	± 0.5	9.0	9.0	± 0.5
W2	1.5	1.5	1.5	1.5	1.5	1.5	1.5	1.5	1.5	1.5	1.5	1.5	1.5	1.5	1.5	1.5	Max.	1.5	1.5	Max.
D0	4.0	4.0	4.0	4.0	4.0	4.0	4.0	4.0	4.0	4.0	4.0	4.0	4.0	4.0	4.0	4.0	± 0.2	4.0	4.0	± 0.2
t	0.7	0.7	0.7	0.7	0.7	0.7	0.7	0.7	0.7	0.7	0.7	0.7	0.7	0.7	0.7	0.7	± 0.2	0.7	0.7	± 0.2
ΔH	0	0	0	0	0	0	0	0	0	0	0	0	0	0	0	0	± 1.0	0	0	± 1.0
ε	1.0	1.0	1.0	1.0	1.0	1.0	1.0	1.0	1.0	1.0	1.0	1.0	1.0	1.0	1.0	1.0	Max.	1.0	1.0	Max.
A	11	11	11	11	11	11	11	11	11	11	11	11	11	11	11	11	Max.	11	11	Max.
Fig. No.	1	1	1	1	1	1	1	1	2	2	2	3	3	2	3	3		3	3,4	

Ammo pack box. (SA, TA)
10 Boxes per carton

Reel pack box. (SR, TR)

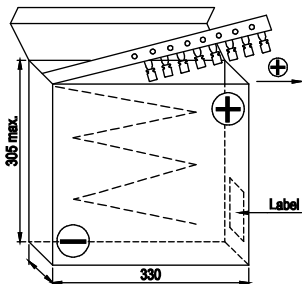

Packaging Quantity

D	3	4	5	6.3	8	10	13
TA, SA	3000	2000	2000	2000	1000	500	250
TR, SR	3000	1500	1200	1000	800	500	500

NOTES:

- The above quantities are typical. Quantities may vary.
- The component will be oriented on the tape so that the positive lead is leading or the negative lead is leading, depending on the customer's request

■ **RADIAL FORMING**

Lead Forming & Cutting Specifications for Radial Type (Unit: mm)

Forming Method	Code	Shape	Dimensions																																																																																
Forming Cut (4 ~ 8)	FC		<table border="1"> <thead> <tr> <th>D x L</th> <th>d</th> <th>F</th> <th>F'</th> <th>H</th> </tr> </thead> <tbody> <tr><td>3 x 5</td><td>0.40</td><td>1.0</td><td>5.0</td><td>5.0</td></tr> <tr><td>4 x 5</td><td>0.45</td><td>1.5</td><td>5.0</td><td>5.0</td></tr> <tr><td>5 x 5</td><td>0.45</td><td>2.0</td><td>5.0</td><td>5.0</td></tr> <tr><td>6.3 ~ 8 x 5</td><td>0.45</td><td>2.5</td><td>5.0</td><td>5.0</td></tr> <tr><td>4 x 7</td><td>0.45</td><td>1.5</td><td>5.0</td><td>5.0</td></tr> <tr><td>5 x 7 ~ 11</td><td>0.5</td><td>2.0</td><td>5.0</td><td>5.0</td></tr> <tr><td>6 x 7 ~ 15</td><td>0.5</td><td>2.5</td><td>5.0</td><td>5.0</td></tr> <tr><td>8 x 7 ~ 9</td><td>0.5</td><td>3.5</td><td>5.0</td><td>5.0</td></tr> <tr><td>8 x 11.5 ~ 20</td><td>0.6</td><td>3.5</td><td>5.0</td><td>5.0</td></tr> <tr><td>10</td><td>0.6</td><td>5.0</td><td>-</td><td>4.5</td></tr> <tr><td>12.5</td><td>0.6</td><td>5.0</td><td>-</td><td>4.5</td></tr> <tr><td>16</td><td>0.8</td><td>7.5</td><td>-</td><td>4.5</td></tr> <tr><td>18</td><td>0.8</td><td>7.5</td><td>-</td><td>4.5</td></tr> <tr><td>22</td><td>1.0</td><td>10.0</td><td>-</td><td>4.5</td></tr> <tr><td>25</td><td>1.0</td><td>12.5</td><td>-</td><td>4.5</td></tr> </tbody> </table>	D x L	d	F	F'	H	3 x 5	0.40	1.0	5.0	5.0	4 x 5	0.45	1.5	5.0	5.0	5 x 5	0.45	2.0	5.0	5.0	6.3 ~ 8 x 5	0.45	2.5	5.0	5.0	4 x 7	0.45	1.5	5.0	5.0	5 x 7 ~ 11	0.5	2.0	5.0	5.0	6 x 7 ~ 15	0.5	2.5	5.0	5.0	8 x 7 ~ 9	0.5	3.5	5.0	5.0	8 x 11.5 ~ 20	0.6	3.5	5.0	5.0	10	0.6	5.0	-	4.5	12.5	0.6	5.0	-	4.5	16	0.8	7.5	-	4.5	18	0.8	7.5	-	4.5	22	1.0	10.0	-	4.5	25	1.0	12.5	-	4.5
D x L	d	F	F'	H																																																																															
3 x 5	0.40	1.0	5.0	5.0																																																																															
4 x 5	0.45	1.5	5.0	5.0																																																																															
5 x 5	0.45	2.0	5.0	5.0																																																																															
6.3 ~ 8 x 5	0.45	2.5	5.0	5.0																																																																															
4 x 7	0.45	1.5	5.0	5.0																																																																															
5 x 7 ~ 11	0.5	2.0	5.0	5.0																																																																															
6 x 7 ~ 15	0.5	2.5	5.0	5.0																																																																															
8 x 7 ~ 9	0.5	3.5	5.0	5.0																																																																															
8 x 11.5 ~ 20	0.6	3.5	5.0	5.0																																																																															
10	0.6	5.0	-	4.5																																																																															
12.5	0.6	5.0	-	4.5																																																																															
16	0.8	7.5	-	4.5																																																																															
18	0.8	7.5	-	4.5																																																																															
22	1.0	10.0	-	4.5																																																																															
25	1.0	12.5	-	4.5																																																																															
Cut (3 ~ 25)	CC																																																																																		
Bending Cut (5 ~ 25)	BC		<table border="1"> <thead> <tr> <th>D x L</th> <th>d</th> <th>F±0.5</th> </tr> </thead> <tbody> <tr><td>5 X 11</td><td>0.5</td><td>2.0</td></tr> <tr><td>6.3 X 11 ~ 15</td><td>0.5</td><td>2.5</td></tr> <tr><td>8 X 11.5 ~ 20</td><td>0.6</td><td>3.5</td></tr> <tr><td>10</td><td>0.6</td><td>5.0</td></tr> <tr><td>12.5</td><td>0.6</td><td>5.0</td></tr> <tr><td>16</td><td>0.8</td><td>7.5</td></tr> <tr><td>18</td><td>0.8</td><td>7.5</td></tr> <tr><td>22</td><td>1.0</td><td>10.0</td></tr> <tr><td>25</td><td>1.0</td><td>12.5</td></tr> </tbody> </table>	D x L	d	F±0.5	5 X 11	0.5	2.0	6.3 X 11 ~ 15	0.5	2.5	8 X 11.5 ~ 20	0.6	3.5	10	0.6	5.0	12.5	0.6	5.0	16	0.8	7.5	18	0.8	7.5	22	1.0	10.0	25	1.0	12.5																																																		
D x L	d	F±0.5																																																																																	
5 X 11	0.5	2.0																																																																																	
6.3 X 11 ~ 15	0.5	2.5																																																																																	
8 X 11.5 ~ 20	0.6	3.5																																																																																	
10	0.6	5.0																																																																																	
12.5	0.6	5.0																																																																																	
16	0.8	7.5																																																																																	
18	0.8	7.5																																																																																	
22	1.0	10.0																																																																																	
25	1.0	12.5																																																																																	
(10 ~ 25)	SD																																																																																		